



---

parallel effects processor **DP/2**

User's Guide

Version 1.0

## DP/2 User's Guide:

Written, designed, and illustrated by: Robby Berman

Copyright © 1995  
ENSONIQ® Corp  
155 Great Valley Parkway  
Box 3035  
Malvern, PA 19355-0735  
USA

Printed in U.S.A.

All Rights Reserved

Please record the following information:

Your Authorized ENSONIQ Dealer: \_\_\_\_\_  
Phone: \_\_\_\_\_

Your Dealer Sales  
Representative: \_\_\_\_\_

Serial Number of Unit: \_\_\_\_\_ Date of  
Purchase: \_\_\_\_\_

Your Authorized ENSONIQ Dealer is your primary source for service and support. The above information will be helpful in communicating with your Authorized ENSONIQ Dealer, and provide necessary information should you need to contact ENSONIQ Customer Service. If you have any questions concerning the use of this unit, please contact your Authorized ENSONIQ Dealer first. For additional technical support, or to find the name of the nearest Authorized ENSONIQ Repair Station, call ENSONIQ Customer Service at (610) 647-3930 Monday through Friday 9:30 AM to 12:15 PM and 1:15 PM to 6:30 PM Eastern Time. Between 1:15 PM and 5:00 PM we experience our heaviest call load. During these times, there may be delays in answering your call.

This manual is copyrighted and all rights are reserved by ENSONIQ Corp. This document may not, in whole or in part, be copied, photocopied, reproduced, translated, or reduced to any electronic medium or machine readable form without prior written consent from ENSONIQ Corp. The DP/2 software/firmware is copyrighted and all rights are reserved by ENSONIQ Corp.

Although every effort has been made to ensure the accuracy of the text and illustrations in this manual, no guarantee is made or implied in this regard.

### IMPORTANT:

“This equipment generates and uses radio frequency energy and if not installed and used properly, that is, in strict accordance with the manufacturer's instructions, may cause interference to radio and television reception. It has been designed to comply with the limits for a Class B computing device in accordance with the specifications in Subpart J of Part 15 of FCC rules, which are designed to provide reasonable protection against such interference in a residential installation. However, there is no guarantee that interference will not occur in a particular installation. If this equipment does cause interference to radio or television reception, which can be determined by turning the equipment off and on, the user is encouraged to try to correct the interference by one or more of the following measures.”

- \* reorient the receiving antenna
- \* relocate the instrument with respect to the receiver
- \* move the instrument away from the receiver
- \* plug the instrument into a different outlet so that the instrument and receiver are on different branch circuits

“If necessary, the user should consult the dealer or an experienced radio/television technician for additional suggestions. The user may find the following booklet prepared by the Federal Communications Commission helpful: 'How to Identify and Resolve Radio-TV Interference

Problems.’ This booklet is available from the U.S. Government Printing Office, Washington, D.C. 20402. Stock No. 004-000-00345-4.”

**CAUTION! Danger of explosion if battery is incorrectly replaced. Replace only with the same or equivalent type recommended by the manufacturer. Discard used batteries according to manufacturer’s instructions.**

In order to fulfill warranty requirements, the DP/2 should be serviced only by an Authorized ENSONIQ Repair Station. The ENSONIQ serial number label must appear on the outside of the unit, or the ENSONIQ warranty is void.

- ENSONIQ, DP/2, DP/4, DP/4+, TS-10, TS-12, and ASR-10 are trademarks of ENSONIQ Corp.

---

## Welcome to the DP/2!

Congratulations on your purchase of the ENSONIQ DP/2. You’ll find it to be a powerful and flexible tool in the creation of exciting sounds.

Your DP/2 comes with two important publications: the DP/2 User’s Guide—which gives you an understanding of the way the DP/2 operates—and the more technical DP/2 Reference Manual, where you can quickly find specific information as you need it. You’re now reading the User’s Guide.

- The first section of the DP/2 User’s Guide provides an easy-to-understand tour through the workings of the DP/2. It’s called *Using the DP/2*.
- *Section 2* discusses *The DP/2 Effects*. In this section, you’ll learn how to customize the DP/2’s effects.
- In the final chapter of the User’s Guide, *Section 3—Quick-Starts*—you’ll find step-by-step instructions on how to set up and use the DP/2 in a variety of specific situations—including, probably, yours. If you can’t wait to start using your DP/2, feel free to jump ahead to this section. When you’re ready to dig in a little deeper, we recommend that you read *Sections 1 and 2* to gain a fuller understanding of the DP/2.

Thank you for purchasing the DP/2.

## Section 1

Using the DP/2

---

## The Basics

The DP/2 is a super effects processor which contains two separate full-powered stereo effects boxes inside. We can think of these internal boxes as Effects named A and B.

The DP/2 can process either a single sound source, or two of them. The DP/2 refers to each of these individual sound sources as a *Source*. When you tell it how many Sources you want it to handle, the DP/2 assigns the two Effects accordingly.

- When you've got one sound source, the DP/2 assigns both Effects to that one Source.

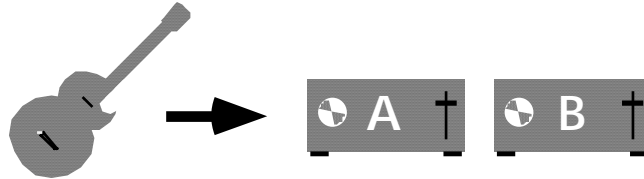

- If you're processing two Sources, the DP/2 assigns one Effect to each.

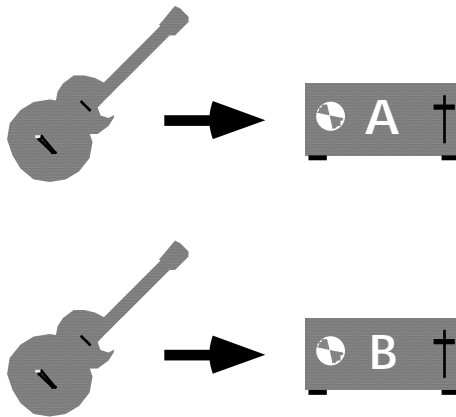

You now have two completely independent Effects, one for each sound source.

---

## Square One

The DP/2 derives its AC power through the included PS-1 power supply.

- Make sure the DP/2's front-panel power button is switched to its "off" (up) position.
- Plug the supplied PS-1 power supply into the DP/2's power socket, located on the right side of the DP/2's rear panel (when viewed from the back).
- Plug the PS-1's power cable into a grounded AC outlet.

You won't need any audio cables as you go through this section of the User's Guide.

- Turn the DP/2 on by pressing the power button.

The User's Guide is designed to work best with a DP/2 as it comes shipped from the factory. *Reinitializing* returns the DP/2's software to the state it was in straight out of the box.

- ⓘ **Important:** If you've already created some new DP/2 effects of your own, or if you've personalized its software in any way, you'll need to save your changes to a MIDI storage device before you reinitialize. Reinitializing clears the DP/2's memory, and your work will be lost. See *Section 5—Storage* in the DP/2 Reference Manual for instructions. Once you've safely stored your data, you'll be ready to reinitialize the DP/2.

## How to Reinitialize the DP/2

- On the DP/2's front panel, locate the {SYSTEM/MIDI} button. Press it, and hold it down.

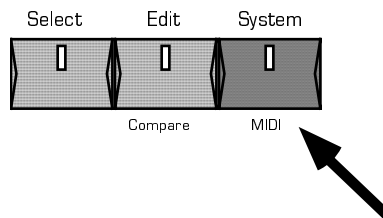

- Without letting go of the {SYSTEM/MIDI} button, press Effect button {B}.

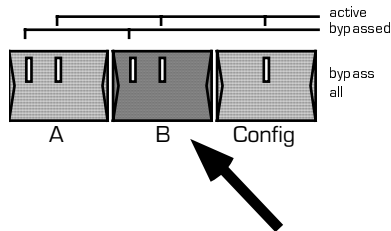

- Let go of both buttons.

On the DP/2's display you'll see:

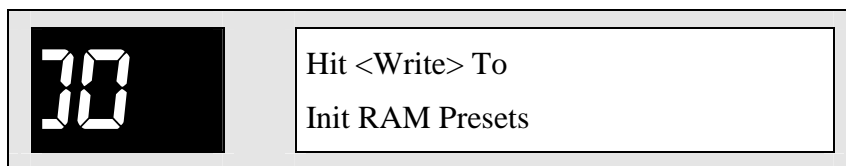

- Press the Right arrow button once.

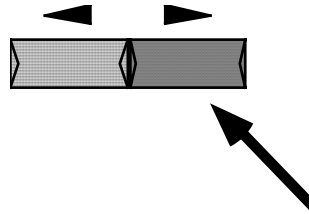

Now the DP/2 will display:

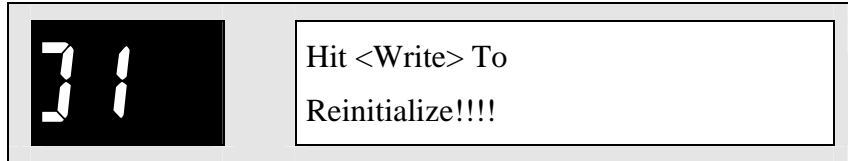

- Press the {WRITE} button once.

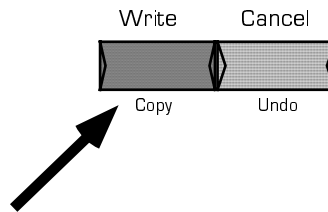

The reinitialization command is executed and the DP/2 briefly flashes its start-up screen.

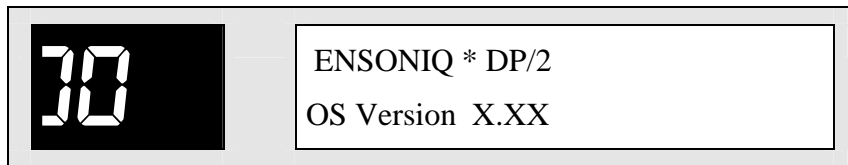

**i**

This is the version number of your DP/2's software

---

## Using the DP/2 with 1 Sound Source

Let's start by imagining that we want to run a single sound source, an electric guitar, through the DP/2. Just as a guitar player would begin by laying out two effect pedals on the floor, we'll set up our two DP/2 Effects.

## Effect A

- Press the DP/2's {EDIT} button.

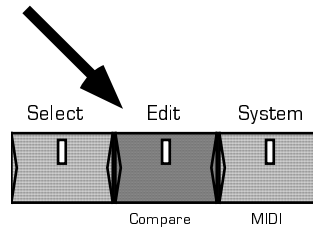

The {EDIT} button's yellow LED lights up.

- Press the {A} button.

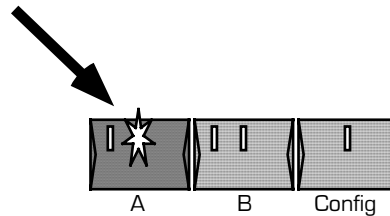

The {A} button's yellow LED lights up.

The large knob on the DP/2's front panel is the data entry knob. We use it to change—or “edit”—the DP/2's settings, which we call *parameters*.

- Turn the data entry knob clockwise to dial in #65, 8 Voice Chorus.

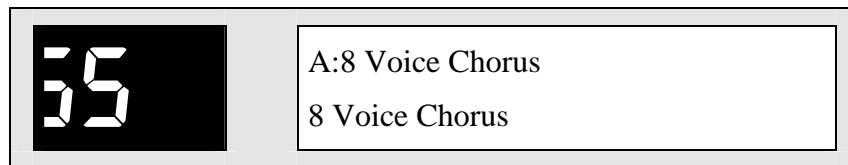

In about a second, the display will change to:

flashing

m

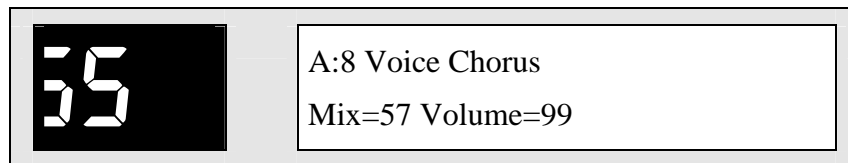

This always happens after you dial in a new effect—the DP/2 prepares itself in the event that you'd like to customize the effect you've just selected. *Section 2* of the User's Guide describes how to edit the DP/2's Effects.

In our scenario, we've just put our first effect pedal, a chorus, down on the floor.



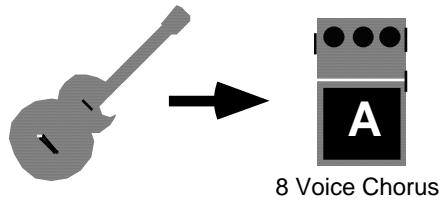

Bear in mind, of course, that the DP/2's effects are of a much higher quality than any actual foot pedal can offer.

Let's set up the second pedal.

### Effect B

- Press the {B} button. Its yellow LED lights.

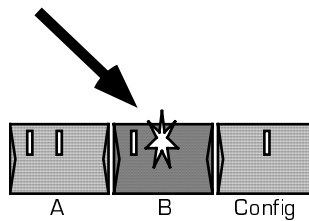

- Turn the data entry knob to dial in #52, Hall Reverb.

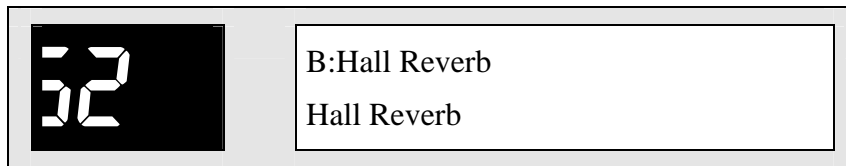

In a moment, the display will once again change as it did the first time—now we have two pedals on the floor.

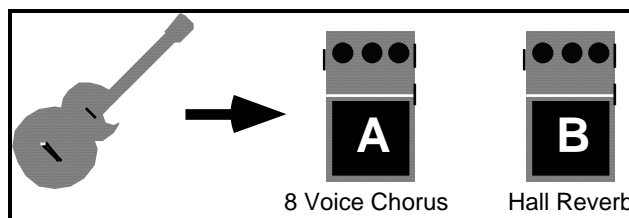

With both of our foot pedals laid out, the next logical step would be to connect our guitar to our Effects. If these were actual foot pedals, we would also have to grab a number of cables to wire them all together.

The DP/2 eliminates the need for all those cables. We tell the DP/2 how we want our Effects connected, and the DP/2 internally "wires" everything together for us.

We refer to such a "wiring" set-up as a "Configuration," or *Config* for short. And since we're currently working with one sound source—our guitar—what we're putting together is called a "1-Source Configuration," or "1-Source Config" for short.

- Press the {CONFIG} button.

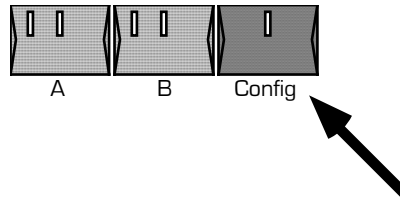

The Config LED lights, and the following display appears:

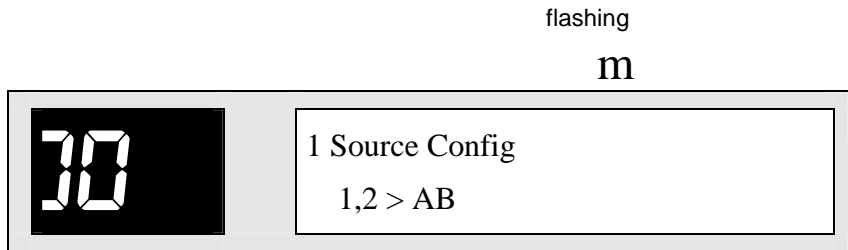

When an area on the display is flashing, that means that it can be changed by turning the data entry knob.

A 1-Source Config is exactly what we're setting up, so we don't need to alter this parameter.

**Note:** In the upper-right-hand corner of the DP/2's front panel are two diagrams depicting how the DP/2 allocates its Effects to the Sources at hand. Since we've got one Source, the green light below the "1 src" (for "1 source") diagram is lit.

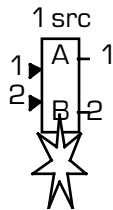

You can see that this single Source uses both of the DP/2's Effects, as shown by the "A" and "B" together inside the single box.

In the DP/2, we move between parameters by using the {<} and {>} buttons.

- Press the {>} button once. The display shows:

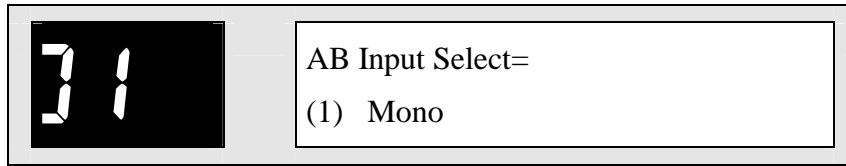

With this parameter, we tell the DP/2 what kind of Source we're using. An electric guitar has a single guitar cord coming out of it, so it's a *Mono* Source. This is already set the way we want it—we needn't change anything here.

The "(1)" on the bottom line of the display shows that the DP/2 will "listen" to Input 1 for a Mono sound source, our guitar—and so that's the jack we'd have to plug it into.

**Note:** There are actually two Input 1 jacks on the DP/2—you can use whichever one of them is more convenient.

There's an input 1 jack on the left side of the front panel of the DP/2, in between the power button and the phones jack:

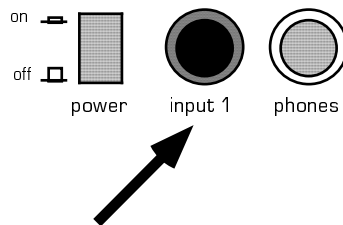

And there's an Input 1 jack on the back panel:

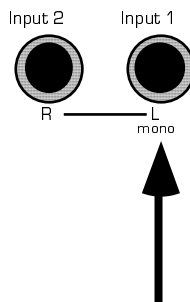

With a 1-source config—as we saw in the front-panel diagram—the DP/2 sends its stereo signal out through Output jacks 1 and 2 on its back panel.

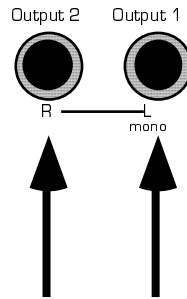

This is true even when we have a mono Source, since all of the DP/2's Effects are themselves in stereo.

The DP/2 has a feature called *intelligent jack switching*—it knows how many cables are plugged into the Output jacks. If it senses that there's no audio cable plugged into Output jack 2, the DP/2 sends everything out through Output 1, in mono.

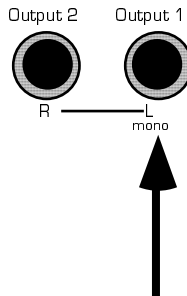

This is handy for musicians who use the DP/2 with a conventional guitar/bass/keyboard amplifier, or in any situation where mono effects are all that's needed.

---

## Saving Your Set-Up

The DP/2 can remember your entire set-up for you—the Effects and the “wiring”—so that you can easily recall it any time you like. We call such a set-up a *Config Preset*. The first step is to write the Config Preset into the DP/2's memory.

Since the {EDIT} and {CONFIG} LEDs are already lit, you don't need to press either of them. When you want to save a Config Preset, both the {EDIT} and {CONFIG} lights have to be on.

- Press the {WRITE} button.

We'll need to find a location within the DP/2's memory in which to store our Config Preset. There are 100 possibilities, organized into two sets of 50 memory locations each. We call these two sets *Bank 1* and *Bank 2*, and we can save Config Presets to locations 00 through 49 in either bank. Locations 40 through 49 in Bank 2 are empty—if you're reluctant to write over any of the DP/2's original straight-from-the-factory Config Presets, you can save up to ten of your own Config Presets there. (Of course, you can always get back the original Presets by reinitializing.)

**Note:** The DP/2 also has an additional 100 Config Presets pre-programmed for you by ENSONIQ. These are stored in locations 50 through 99 in each of the two banks, and can't be overwritten with new set-ups.

Let's save our Config Preset to location 00, the first memory location in Bank 1.

- Turn the data entry knob until the display looks like this:

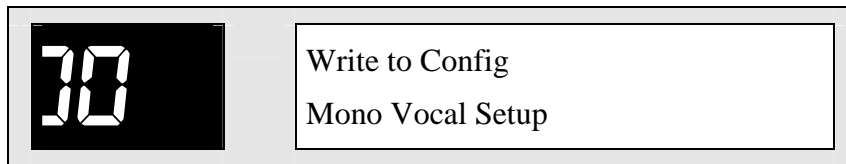

"Mono Vocal Setup" is the Config Preset we'll be replacing.

- Press the {WRITE} button again to confirm the location we've chosen. The display shows:

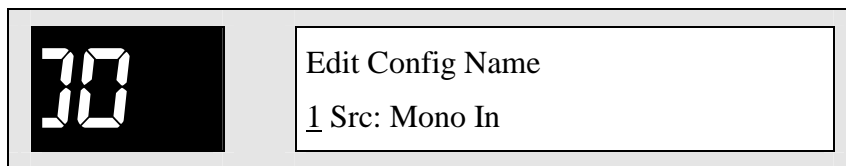

When the DP/2 is showing this display, we can name our Config Preset.

**Note:** The first "1" on the lower line of the screen is underlined. When a character on the DP/2's display is underlined, it can be changed with the data entry knob (just as we found earlier with flashing parameters).

As you'll soon see, the numeral "1" is just what we want here, so we needn't change it.

- Press the {>} button once.

This causes the blank space to be underlined—and therefore changeable. But a blank space happens to be what we want here, also.

- Press the {>} button again.

The underline moves to the "S".

- Turn the data entry knob counter-clockwise to locate the capital "G."
- By continuing to use the {>} button to move the underline and the data entry knob to dial in characters, name the Config Preset "1 Guitar & 2 FX." ("FX" is a common music-industry abbreviation for "effects.")

If you make a mistake anywhere, you can always use the {<} button to go back and fix it.

When you're done, the display will look like this:

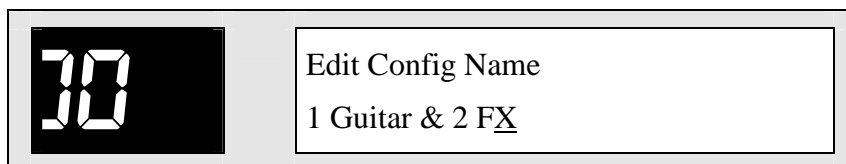

- Press the {WRITE} button again and the DP/2's screen will flash:

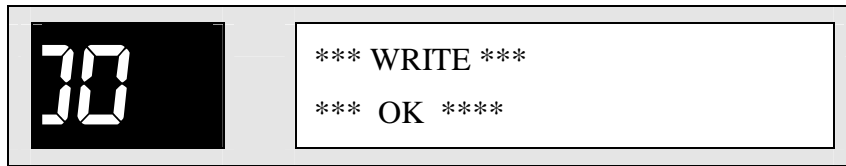

The DP/2 has saved your set-up, the Config Preset called “1 Guitar & 2 FX,” to memory location 00.

Congratulations! You’ve just created and saved your first DP/2 Config Preset.

---

## Using the DP/2 with a Single Stereo Sound Source

Suppose you want to use the DP/2 with a keyboard instead of a guitar. The main difference here would be that most electronic keyboards are stereo instruments, with two outputs—our guitar only had one.

Let’s start in the same way we did with our guitar: by setting up our two Effects.

### Effect A

When you want to dial in a new Effect, the {EDIT} LED must be on. Since it’s already lit, you don’t have to press {EDIT}.

- Press the Effect {A} button.
- Use the data entry knob to call up #78, Flanger.

This sets up our first keyboard Effect:



## Effect B

- Press {B}.
- Dial in #52, Hall Reverb.

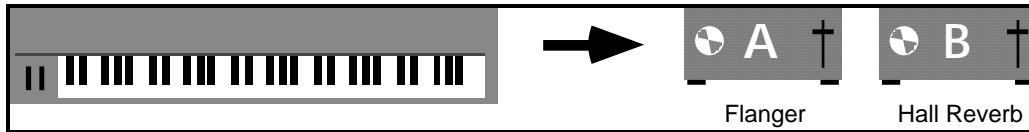

You'll notice that this is the same reverb we used with our guitar set-up. That's fine: you can use the same Effect in as many Presets as you like. You can also use two of the same type of effect together, if you'd like—two different reverbs, for example.

Now we need to tell the DP/2 that we'll have two cables coming in from our stereo keyboard.

- Press {CONFIG}.

Once again, the display shows:

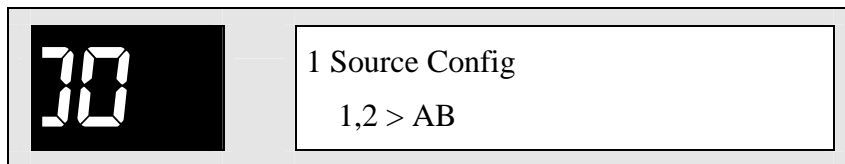

Since we still have only one sound source—our keyboard—this setting is still appropriate.

**Important:** “Number of Sources” does not mean “number of inputs.” Even though our stereo keyboard has two cables coming into the DP/2, it's still just one sound source. It's a *Stereo* Source. Telling the DP/2 how many sound sources you want to process simply tells it whether or not to divide its pair of Effects.

- Press {>} once. The display shows:

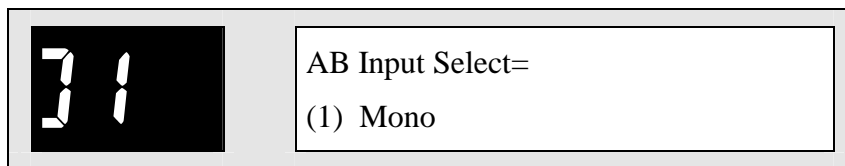

The number in the lower left-hand part of the display tells us that the DP/2 will “listen” to Input jack 1 for a mono sound source.

Our keyboard, however, is stereo. This is where we let the DP/2 know that we'll be plugging in two cables from our keyboard's stereo output.

- Turn the data entry knob counter-clockwise so that the display reads:

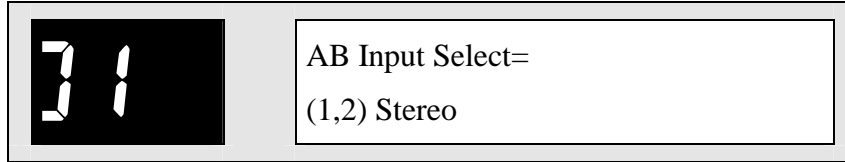

The DP/2 will now “listen” to Inputs 1 and 2 for our stereo sound source.

We’re now ready to save our keyboard Config Preset.

- Press {WRITE}.
- Turn the data entry knob to move to location 01—we’ll put it right next to our guitar set-up for convenience. The display shows:

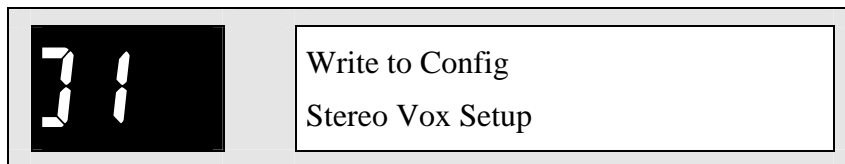

- Press {WRITE} again to confirm the location.

Now we can name the new set-up.

- Using the {<} and {>} buttons and the data entry knob—just as we did earlier—name this keyboard Config Preset “Keyboard & 2 FX.”

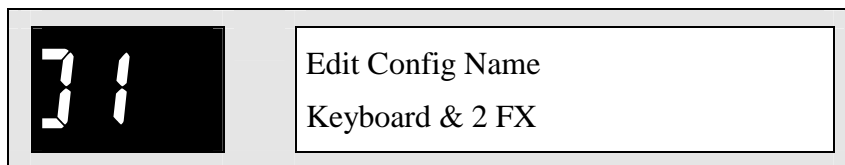

- When you’re done, press the {WRITE} button again, and the DP/2 will briefly display:

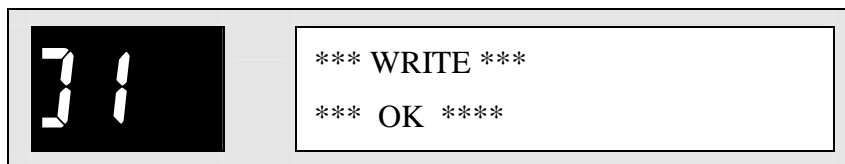

You’ve just saved your second Config Preset. Now that your guitar and keyboard Config Presets are stored in the DP/2’s memory, you can recall them easily. And since the DP/2 retains its memory even when it’s been turned off, they’ll be there the next time, and every time, you power up your DP/2, until you yourself erase them or reinitialize the DP/2.

---

## Recalling Config Presets



- Press the {SELECT} button. Its LED lights up, and the {EDIT} light goes out.
- Since the {CONFIG} light is already on, you don't need to press the {CONFIG} button.
- Turn the data entry knob clockwise.

As you scroll upwards through the Config Presets, you'll see the numbers increment from 00 to 99, and then start all over again from 00. The first 100 are the Config Presets in Bank 1 and the next 100 are those in Bank 2. The presence—or absence—of a dot in the lower right-hand corner of the number display tells you which bank you're in.

The numeric display for the Config Presets in Bank 1 look like this:

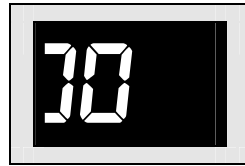

**i**  
no dot

The Config Presets in Bank 2 have a dot in the lower right-hand corner of the number display:

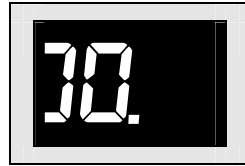

**i**  
dot

**Note:** Sometimes you may see another small dot between the two numerals. This tells you that the DP/2 is receiving MIDI information. *Section 4—System/MIDI* in the DP/2 Reference Manual discusses using MIDI with the DP/2.

- Dial up Config Preset 00 in Bank 1 (no dot).

There's our guitar set-up, 1 Guitar & 2 FX.

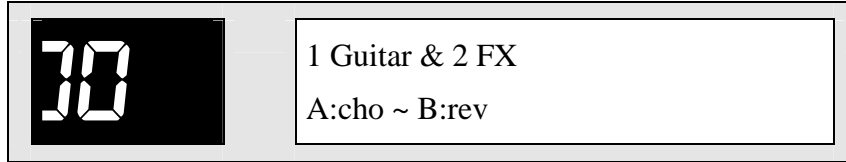

The bottom line of the display is showing us abbreviations for the effects we're using in this Config Preset.

- Dial in 01 in Bank 1—it's our keyboard Config Preset, Keyboard & 2 FX.
- Go back to 1 Guitar & 4 FX.

The {SELECT} light is flashing. When you select a new Config Preset, the DP/2 waits for you to confirm your choice before it actually loads in the set-up. This flashing light tells you that the DP/2 is awaiting your confirmation.

- Press {SELECT} again to confirm your choice of 1 Guitar & 2 FX.

The {SELECT} LED stops flashing. That's all there is to it!

**Note:** When we wanted to recall our Config Presets, we only had to press {SELECT} and dial in our choice, since the {CONFIG} light was already lit. The important thing to remember when recalling Config Presets is that both the {SELECT} and {CONFIG} lights have to be on before you can select set-ups. You may need to press one or both of the buttons to get them to light.

---

## The Flexible DP/2

The DP/2 can produce many different types of sounds by changing the relationships between its Effects. Let's examine a couple of the possibilities in order to see how we can take advantage of the DP/2's terrific flexibility.

### Serial Effects

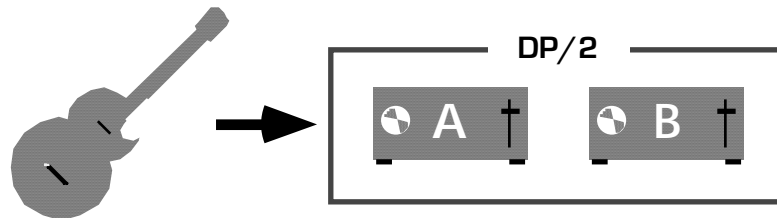

- Press {EDIT}.

Since the {CONFIG} button's LED is already lit, you don't have to press that.

**Note:** Whenever you want to work on your set-up's "wiring," both the {EDIT} and {CONFIG} lights must be lit.

The display shows:

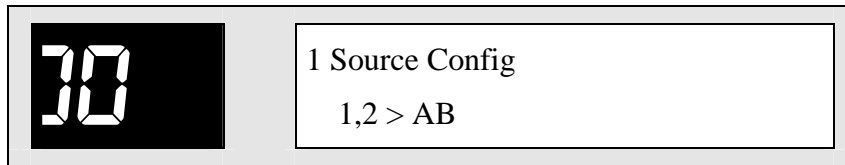

This is apropos— we’ve got one Source, a guitar.

- Press {>} once—we’ve got to tell the DP/2 what kind of input we need.

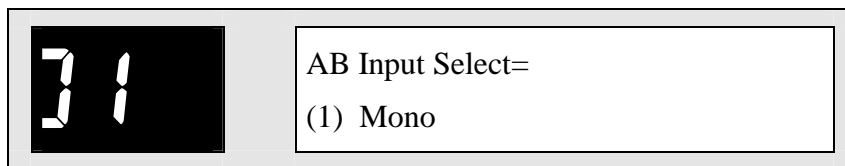

This is also set correctly for our guitar, with its single cable.

- Press the {>} button once more—the display shows:

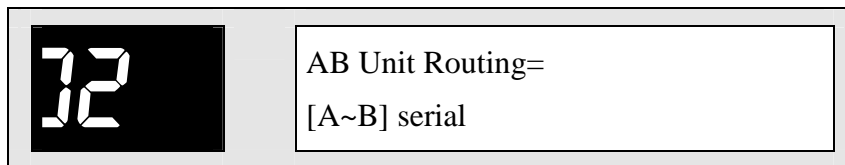

This display gives us the opportunity to determine the relationship—or “routing”—between Effects A and B.

**Note:** Some of the DP/2’s displays refer to the two Effects as *Units*.

There’s another term on the bottom line of the display which we haven’t encountered before. When Effects are “wired” one after the other in a series, we say that they have a *serial* relationship.

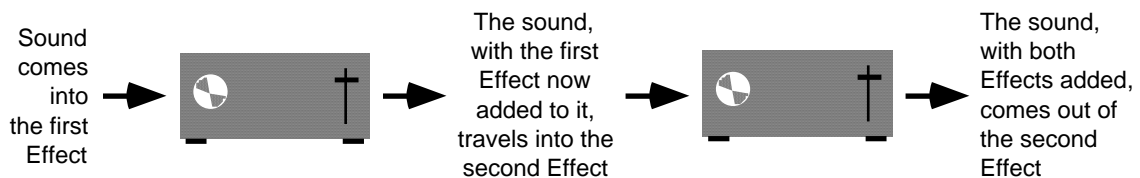

**Note:** Since the DP/2’s Effects are stereo, so is the sound traveling between them. We’re showing the sound here with single arrows for the sake of clarity.

When a sound travels through Effects arranged in a series, it becomes more and more processed. This is often desirable, since it allows you to polish up the sound a bit more each time it passes through an Effect.

For instance, a compressor and a reverb wired in series might be helpful in processing a lead vocal. The vocal would first go through the compressor to smooth out any volume fluctuations. After that, the tightened-up vocal could go on to a reverb, where an ambience of your choice could be added.

On the DP/2 displays, we use a right-pointing arrow—“~”—as shorthand for the word “serial” when showing the relationship between Effects. We can see this symbol on the current display.

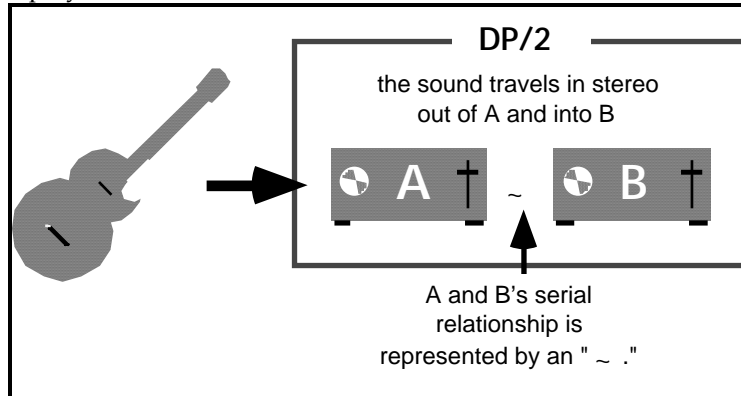

When Effects A and B have a serial relationship, the sound comes into the DP/2, travels through Effect A, then Effect B, and then out of the DP/2's stereo Outputs 1 and 2.

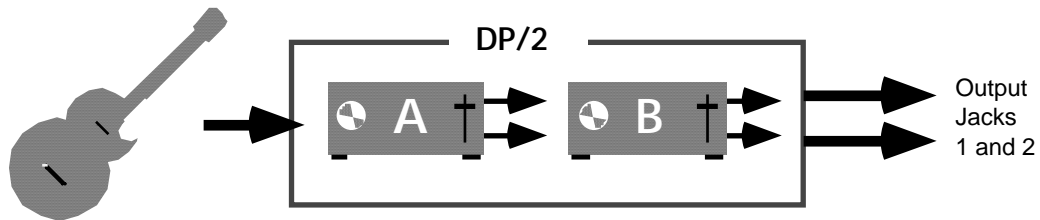

Let's save our serial setup in location 02 in Bank 1.

- Press {WRITE}.
- Turn the data entry knob until the display looks like this:

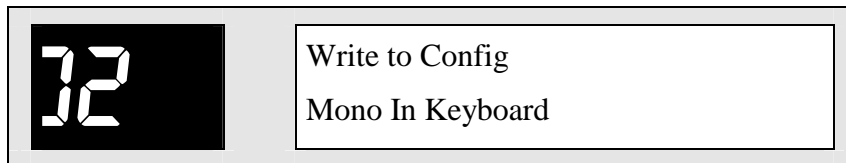

- Press {WRITE} again.

We'll name our Preset using the shorthand symbol we've just learned: ~, for a serial relationship between Effects A and B.

- With the data entry knob and {>} button, set the display to look like this:

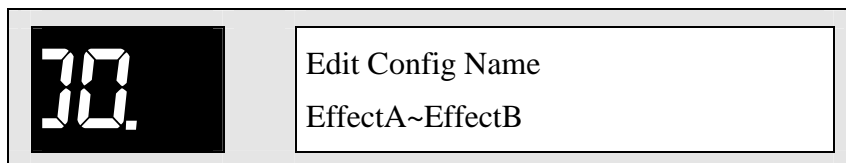

The name tells it all: the arrow between Effect A and B shows that they have a serial relationship to each other.

- Press {WRITE} again.

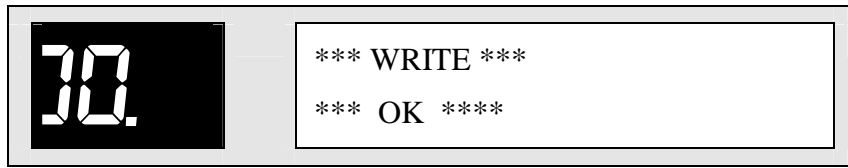

## Parallel Effects

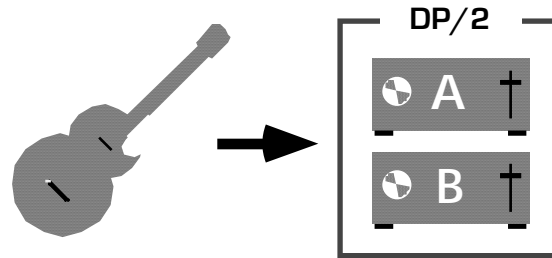

- Press {>} twice so that the display once again shows:

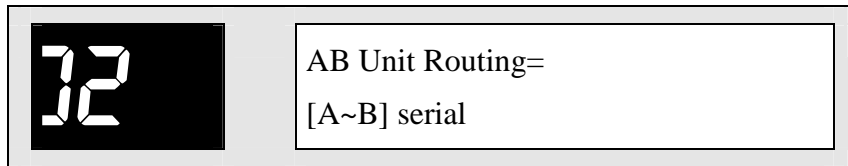

- Turn the data entry knob clockwise so that the display looks like this:

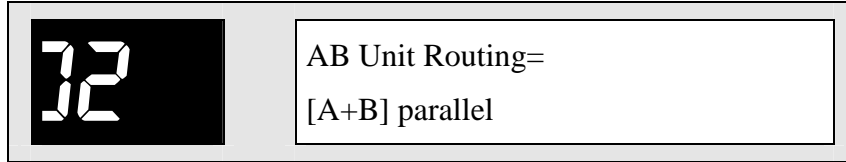

The word “parallel” now appears on the bottom line of the display. We can also see that the arrow in the parentheses between “A” and “B” has changed to a plus sign (“+”). This is the symbol we use to show a *parallel* connection between Effects.

In a parallel connection between Effects, both Effects process the sound separately and at the same time.

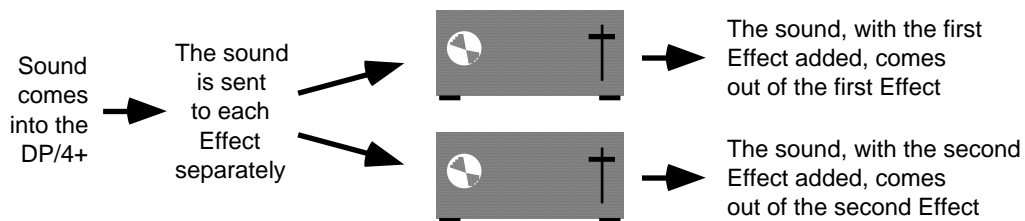

Parallel processing is useful when you want to add several distinct Effects to a sound but not to each other. There are times when running Effects in parallel is the best way to keep your sound clear and clean.

Here’s an example. Suppose you’ve decided to run a lead vocal through a flanger Effect. You’d also like to add a touch of reverb. The swirling “swoosh” added by the first Effect—the flanger—sounds good, but it also makes the singer’s lyrics less distinct. If you run this flanged vocal through a reverb, the lyrics will become even harder to make out.

A much better approach would be to arrange the Effects in parallel, where the vocal goes separately to the flanger and reverb. You can then combine the two very different sounds together, so that the clean vocal with its touch of reverb is mixed together with the flanged version.

By the way, there are a few other relationships we can set up between our Effects. You can learn more about them in the DP/2 Reference Manual’s *Section 3—Config Parameters*.

When we dialed in “parallel” a moment ago, here’s what we set up:

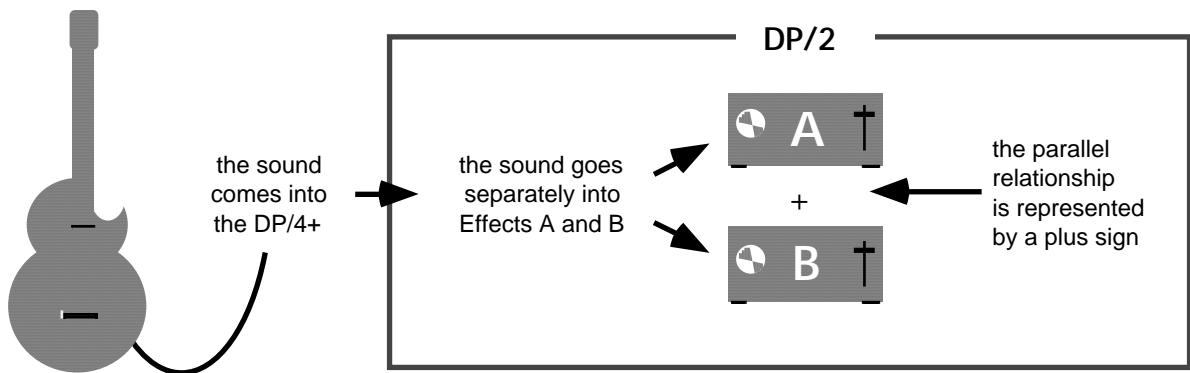

The DP/2 digitally copies the incoming sound, and then sends one copy to each Effect. Since the copies are digital, they both sound every bit as good as the original.

This is how sound will now travel through the DP/2:

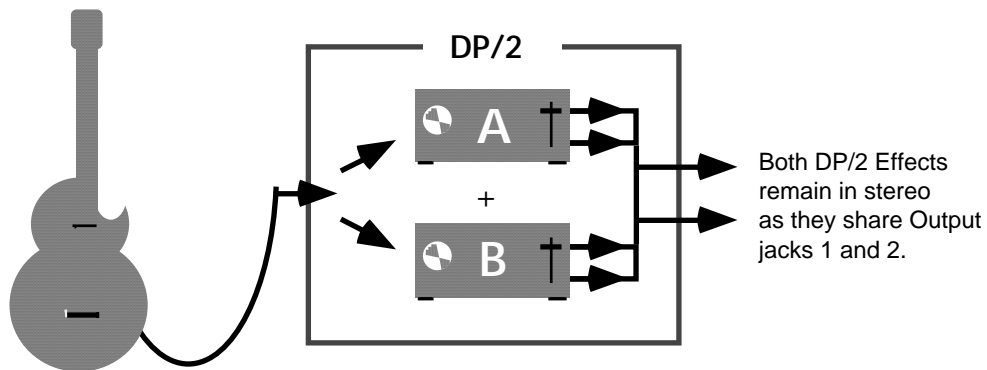

Let’s save our new parallel effects Config Preset to location 00—in Bank 2—this time.

- Press {WRITE}.
- Turn the data entry knob until the display looks like this:

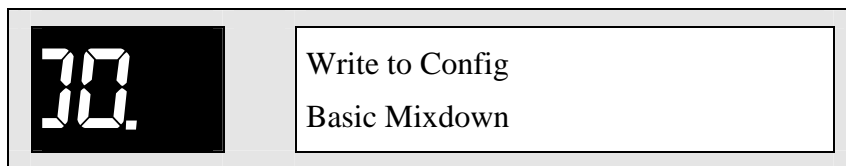

i

The dot tells you this Config Preset is in Bank 2

- Press {WRITE} again.

This time we’ll use the symbol for a parallel relationship—+—in our Config Preset’s name.

- With the {>} button and data entry knob, set the display to look like this:



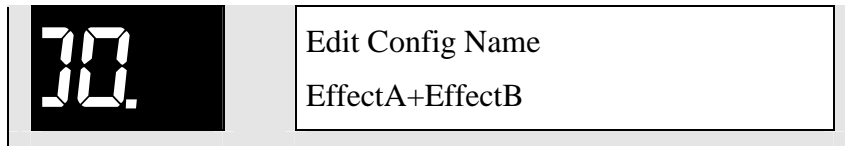

- Press {WRITE} again.

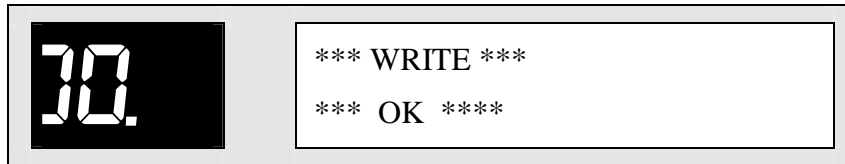

...is displayed.

---

## (B)ypass and (K)ill

In the DP/2, it's easy to instantly turn Effects off.

- Press the {>} button four times to get to Edit Config Parameter 04.

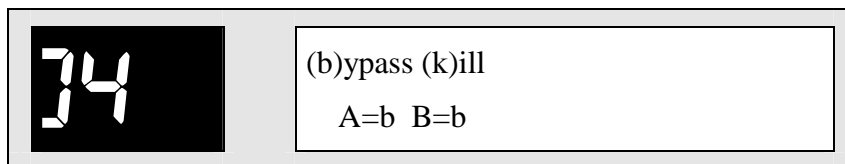

- Press the {A} button twice—its red LED goes on.

You can also set up the DP/2 so that pressing a footswitch or sending a command over MIDI will accomplish the same thing.

- Press the {CONFIG} button.

When an Effect's red light is on, the DP/2 looks to the parameter we've now got displayed to learn what we want done with the sound going through the Effect. We can see that Effect A is currently set to "b," which stands for *bypass*.

When an Effect is bypassed, sound passes through it without the effect being added. In essence, bypassing turns the effect off.

The B Effect is also set to "b." Since its red LED isn't on, it's not currently bypassed.

Effects can also be set to "k," which stands for "kill." When an Effect is set to "k"—and its red light is on—sound travels into the Effect and is stopped. Nothing at all comes out of the Effect.

You can always tell whether an Effect is bypassed or killed by whether or not its red LED is flashing or solidly lit. When an Effect is killed, its red LED flashes on and off. If the red light's on, but not flashing, the Effect is bypassed.

- Press {A} twice more to turn its red light off and "un-bypass" it.



**Note:** When an Effect's yellow light is on, you only need to press the Effect's button once to turn the red LED off or back on. You can also bypass or kill both of the Effects simultaneously by pressing the {CONFIG} button until both of their red LEDs light at once. Pressing {CONFIG} again will switch them back off.

---

## Using the DP/2 With more Than One Sound Source

So far, we've been talking about how to use the DP/2 with a single sound source. But the DP/2 can process two completely different Sources at the same time.

### Setting Up a 2-Source Config Preset

Let's create a Config Preset that will simultaneously process a guitar and a bass.

- If the {CONFIG} LED isn't already lit, press {CONFIG}.
- Press {<} four times to go to Parameter 00.

This time we have two Sources—the guitar and the bass.

- Turn the data entry knob clockwise to change the top line of the display to "2 Source Config."

After about a second, the display will briefly flash:

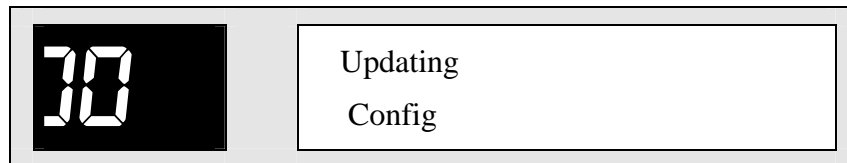

...and then change to:

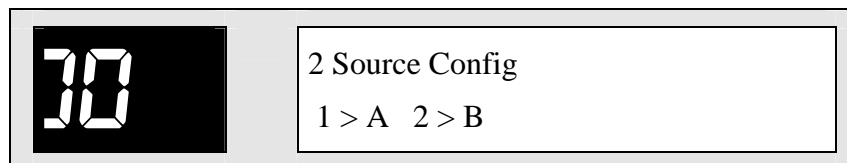

Since the DP/2 now has two Sources to process, it has assigned one Effect to each Source. The display shows us that Effect A "listens" to Input 1, and Effect B "listens" to Input 2.

**Note:** The green LED below the 2 src ("2 source") diagram on the DP/2's front panel lit up when we changed the number of Sources. This shows clearly that the Effects have split into two distinct pairs.

Let's plan our sonic strategy.

We'll process the guitar through Effect A, so we'll have to plug it into Input 1. And let's run it through a guitar amp simulation.

The bass will go through Effect B, so we'll plug it into Input 2. Let's flange the bass.

Now that we've decided what we want to do, let's set up our Effects. The {EDIT} LED is already lit, so we don't have to press {EDIT} .

For the guitar:

- Press {A} and use the data entry knob to dial in #52 in Bank 2, Guitar Amp 1.

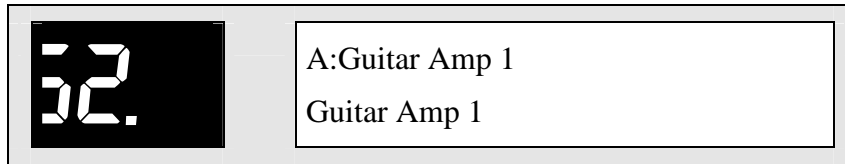

i

The dot tells you you're in Bank 2

Just as there are two Banks of Config Presets, there are also two banks of effect presets, those in Bank 2 being signified—as before—by a dot in the lower right corner of the number display.

For the bass:

- Press {B} and dial in #78, Flanger, in Bank 1 (no dot).

The DP/2 provides you with helpful customizing options relevant to the number of sound sources you're dealing with. New wiring options appear, and unnecessary parameters are removed.

In this case, we no longer have to choose whether our inputs are mono or stereo—since each Source uses only a single Input jack, they're both mono. Similarly, we don't have to designate a relationship between Effect A and Effect B anymore. With two Sources, they're completely independent of each other.

At the same time, the DP/2 now offers some special flexibility in how we want our two Sources to use the DP/2's Outputs.

- Press {CONFIG}.
- Press the {>} button once. The display shows:

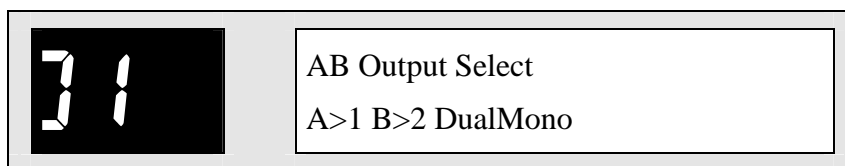

When this display is set to "Dual Mono"—as it currently is—Effects A and B exit the DP/2 through Output jacks 1 and 2 as two individual mono Effects.

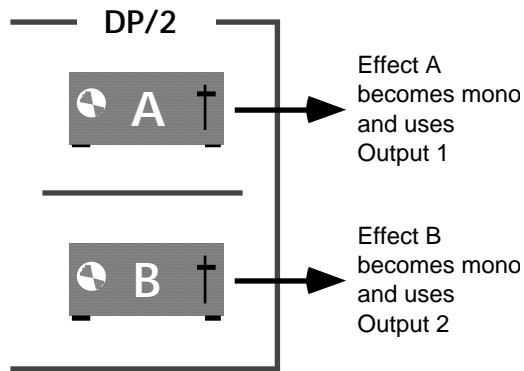

- Turn the data entry knob clockwise. On the display we now see:

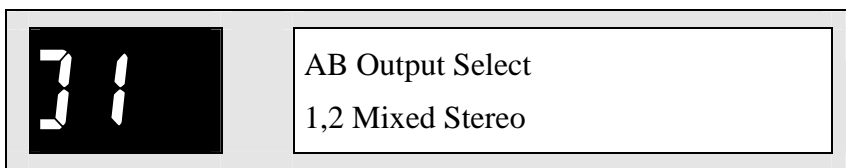

When the AB Output Select is set to Mixed Stereo, the A and B Effects, though still separate, remain in stereo and share Outputs 1 and 2, as shown in the following illustration.

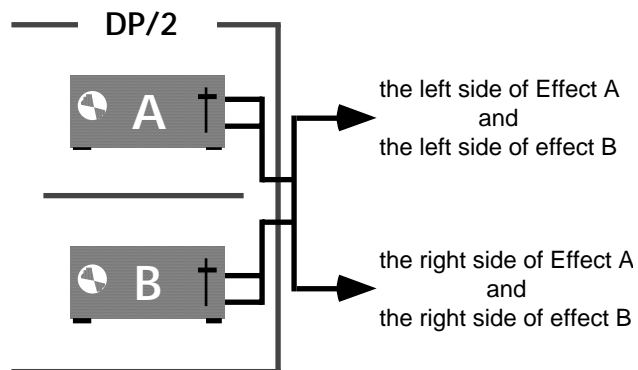

Our guitar/bass set-up is now complete:

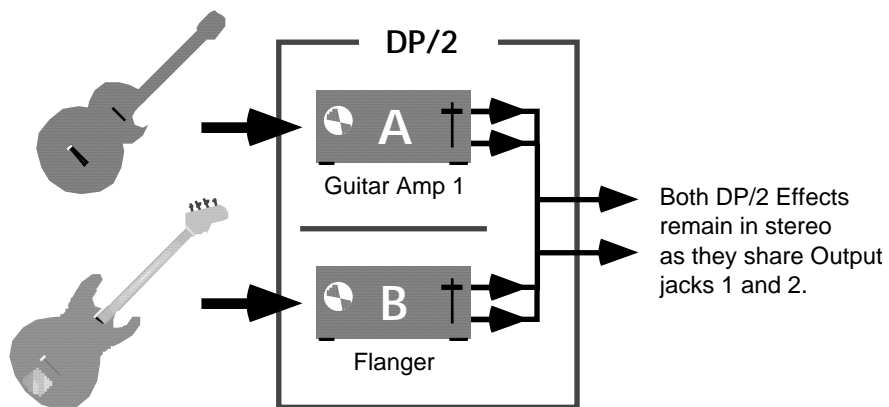

And, as always, after you've set up a Config Preset, you'll want to save it—this time, anywhere you'd like. Let's name this final set-up "That's All Folks."

---

## A Quick Summary

When you use the DP/2, you work with something called a Config Preset. Config Presets are simply DP/2 set-ups.

These set-ups include information on things such as what kind of sound sources you want the DP/2 to process and how many of them you'll be using, what Effects you want to use, and how you want it all connected. Config Presets are stored in the DP/2's internal memory. ENSONIQ has pre-programmed 200 Config Presets for you, and you can create your own as well.

---

## Moving On...

In our next section, *The DP/2 Effects*, you'll learn how to customize the DP/2 Effects to suit your own needs.

# Section 2

## The DP/2 Effects

### Inside this Section

Overview.....	1
Setting Up.....	2
1-Unit Presets.....	4
2-Unit Presets.....	11

---

## Overview

Inside the DP/2 are two high-quality effects processors. Each one of these is called a Unit . (In *Section 1* of the User's Guide, we referred to them as "Effects.")

Each effects processor is called a "Unit."



Each Unit has a button on the DP/4+'s front panel.

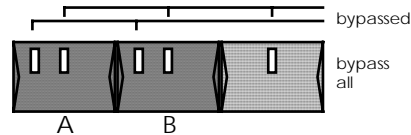

The DP/2 can process one or two sound sources at a time.

Note: A Source can be any number of things: an instrument, the bus of a mixing console, or the outputs from a compact disc or cassette player, for example. A Source can be either mono or stereo—it's just one single "thing." The number of inputs does not equal the number of Sources.

If you haven't already read it, *Section 1* of the User's Guide explains how to set up the DP/2 for the number of Sources you intend to use.

The effect Presets in the DP/2's memory are stored individually and in pairs which work well together. This is also the way they're used.

When the DP/2 processes two Sources, it allocates the two Units so that each one processes a single Source. Each Unit has its own separate effect, called a *1-Unit Preset*.

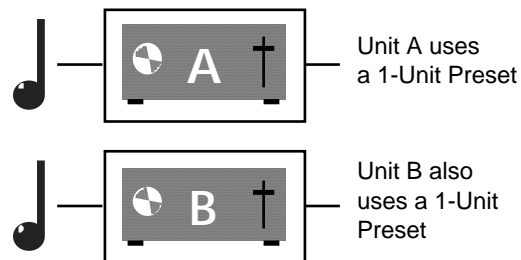

When there a single Source, both Units work together to process that one Source. This pair of Units uses a *2-Unit Preset*, as in the following illustration:

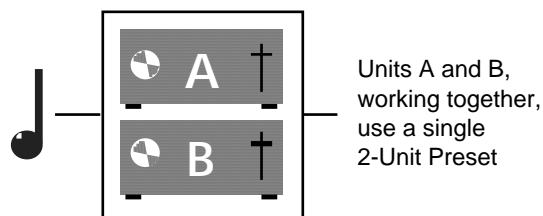

---

## Setting Up

We're going to explore the DP/2's effect Presets using stereo headphones, so you'll need a pair of those. (If you prefer to connect the DP/2 to your mixer or home stereo system for listening, see the DP/2 Reference Manual's *Preface* for details on making those connections.)

- Make sure the DP/2's power button is in the "off" (up) position. It's in the lower left-hand corner of the DP/2's front panel.
- Connect the included PS-1 power supply to the jack on the right side of the rear panel of the DP/2 (when viewed from the back).
- Connect the other end of the PS-1 to a grounded AC outlet.
- Press the DP/2's power switch to turn the DP/2 on.
- Locate the input 1 knob on the front panel of the DP/2.

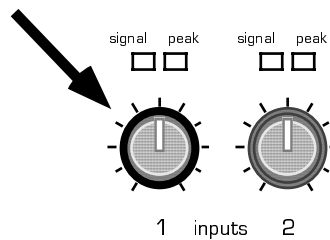

- Turn the knob all the way down (counterclockwise).
- Locate the outputs knob, just to the left of input 1.

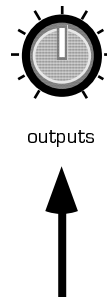

- Turn it all the way down.
- Plug your headphones into the jack labeled phones on the DP/2's front panel.

Connect an electrified instrument—an electric guitar or synthesizer, for example—to the DP/2's front-panel input 1 jack. You could also use the output of an audio device such as a CD or cassette player—in that case, you'll likely need an RCA phono-to-1/4" phone plug adapter.

- Insert your instrument's 1/4" phone plug into the input 1 jack on the front panel of the DP/2.

Let's set volume levels. Put your headphones on.

- Make some noise—play your instrument or press the Play button on your CD or cassette player.

- As you play your instrument, etc., turn the input 1 knob clockwise until the red peak LED just above it is flickering occasionally. This LED warns you that your input signal is approaching the point where it will be too loud.

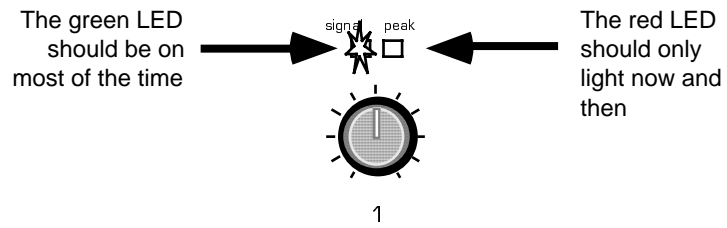

- Turn the outputs knob up slowly to find a comfortable listening level.

---

## 1-Unit Presets

### Selecting 1-Unit Presets

- Press the {SELECT} button if its LED isn't already lit.

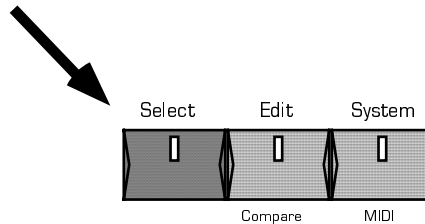

- Press the {CONFIG} button if its light isn't already on.

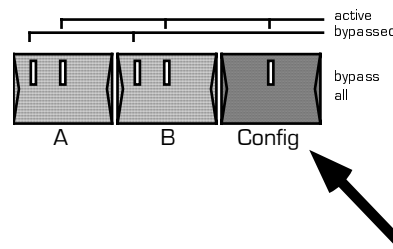

The {SELECT} and {CONFIG} LEDs must be on in order to select 1-Unit Presets.

- Turn the data entry knob until the display shows:

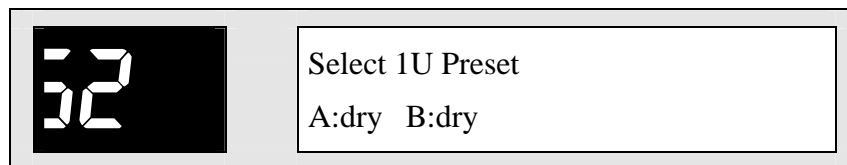

The {SELECT} light is flashing—this means that the DP/2 is waiting for you to confirm your selection.

- Press {SELECT} once more to confirm your choice.

We're going to explore 1-Unit Presets by working with the one occupying Unit A.

- Press the {A} button—its yellow LED remains lit, while those in the {B} and {CONFIG} buttons go out ({B}'s red LED continues to flash on and off).

**Note:** If you wanted to work with a 1-Unit Preset in Unit B, you would have pressed its button. Whichever one you pressed would have remained lit, while the other yellow lights would have gone out.

If the Unit you intend to work with ever has its red LED lit, press the Unit's button once or twice so that only its yellow light is on—otherwise, you won't hear it.

The display shows:





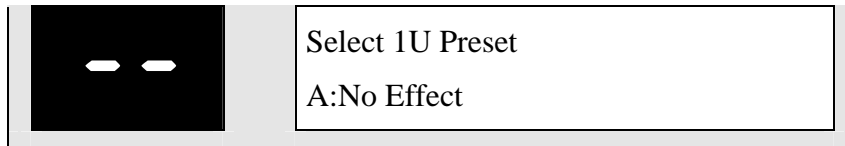

- Turn the data entry knob counter-clockwise until the display reads:

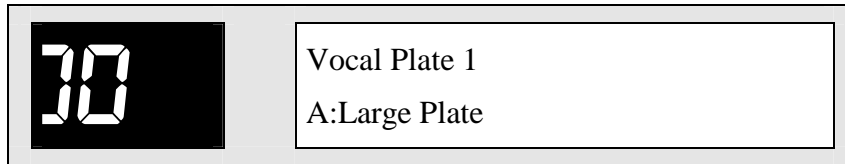

This is “Vocal Plate 1,” the first of the 200 1-Unit Presets stored in the DP/2’s memory.

Note that the {SELECT} button is again flashing—the DP/2 is awaiting confirmation of your 1-Unit Preset selection.

- Press {SELECT} to confirm.

Now you can play your instrument, etc. to hear what the 1-Unit Preset “Vocal Plate 1” sounds like.

When you’re done listening to “Vocal Plate 1,” you can access the other 199 1-Unit Presets.

The 1-Unit Presets are divided into two groups of 100 Presets each. These groups are called *banks*. The Presets in each bank are numbered from 00-99.

- Turn the data entry knob clockwise.

As you turn the data entry knob, you’ll see the Preset numbers increment from 00 to 99 in Bank 1, and then start over again with 1-Unit Preset 00 of Bank 2.

You can easily tell which bank you’re in by the presence—or absence—of a dot in the lower right-hand corner of the numeric display.

The 1-Unit Presets in Bank 1 look like this:



The 1-Unit Presets in Bank 2 have a dot to the right of the displayed number:



dot

**Note:** Sometimes you may see another small dot between the two numerals. This tells you that the DP/2 is receiving MIDI information. *Section 4—System/MIDI* in the DP/2 Reference Manual discusses using MIDI with the DP/2.

- Dial in any of the 1-Unit Presets.
- Press the flashing {SELECT} button to confirm your choice.
- Send the DP/2 some sound.

### Editing 1-Unit Presets

- When you've finished listening to the 1-Unit Presets, go back to Preset 00 in Bank 1—"Vocal Plate 1"—and press the flashing {SELECT} button to confirm.
- Press the {EDIT} button.

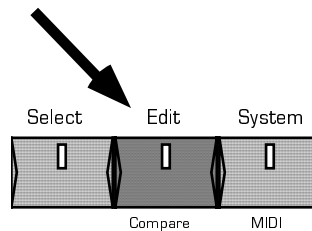

The display changes to:

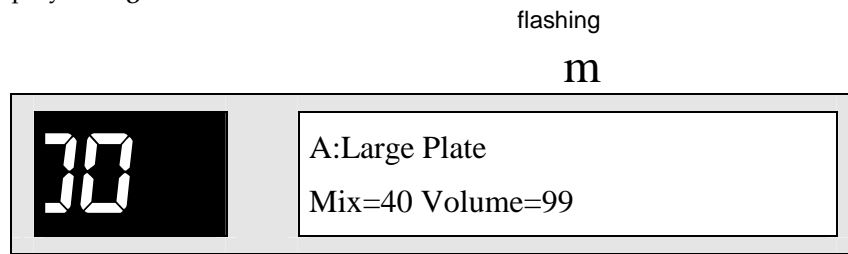

We can now customize "Vocal Plate 1."

Note that the top line in the display is flashing. Many aspects of the DP/2's software can be changed to suit your needs—we call these *parameters*. When a parameter is flashing—like the top line in the display—it is selected for editing. We use the {<} and {>} arrow buttons to select each parameter, and then we use the data entry knob to change the parameter's setting.

Since the first effect parameter is already flashing, it's ready to edit.

- Turn the data entry knob slowly clockwise.

What you're now seeing on the bottom line of the display are the names of all the 1-Unit Presets contained in the DP/2's memory. The top line of the display shows the name of the *algorithm* each Preset is based on—algorithms are the complex mathematical formulae that create the sounds you hear in the DP/2. You may have noticed that a moment or so after you stop turning the data entry knob, the display changes somewhat. What's happening is that the DP/2 is automatically setting up the 1-Unit Preset you've

picked. When this occurs, The bottom line shows the new Preset's Mix and Volume settings.

You can easily undo any changes you've made by pressing the {UNDO} button.

- Press the {UNDO} button.

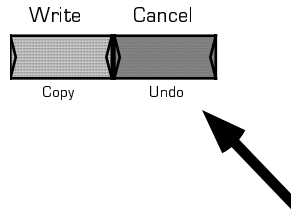

Let's edit some other parameters.

- Press the {>} button once.

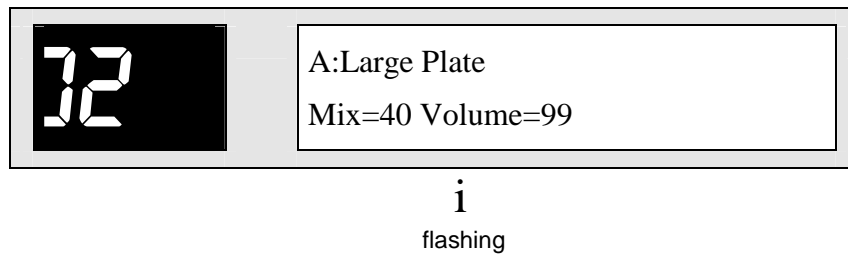

Now the Mix parameter is flashing—we've selected it for editing. This parameter determines how much of the effect will be added to your original sound.

- Turn the data entry knob up to 99, down to 00 and back to 50.

You've just turned Unit A's effect mix all the way up, down and back to the middle.

Each effect in the DP/2 has a number of parameters—many more than those we're currently seeing. Once you start editing an effect, the large red number to the left of the display becomes the number of the parameter that's selected for editing. For more information on the parameters provided for each of the DP/2's effects, see *Section 2—Effect Algorithms* in the DP/2 Reference Manual.

- Press the {>} button twice.

This takes us to the third parameter for this effect.

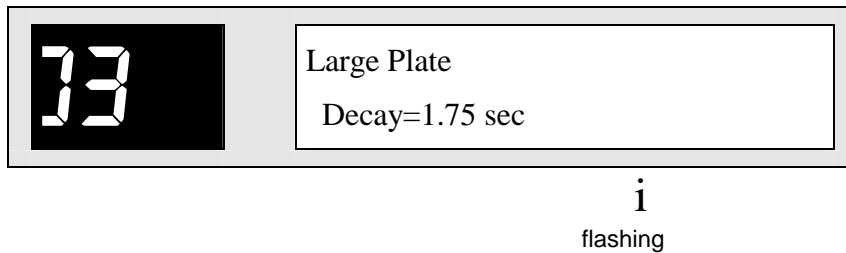

This is the Decay time setting for our reverb. The time field is flashing—and therefore selected. Use the data entry knob to change this value if you'd like. To find this effect's other parameters, continue to press the {>} button. When a parameter is flashing, you can alter its setting with the data entry knob.

You can also, of course, go back to previously viewed or edited parameters by pressing the {<} button.

### Saving 1-Unit Presets

Once you've customized a 1-Unit Preset, you can write it into the DP/2's memory and the DP/2 will remember it for you.

- Press the {WRITE} button.

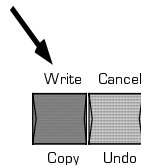

The display shows:

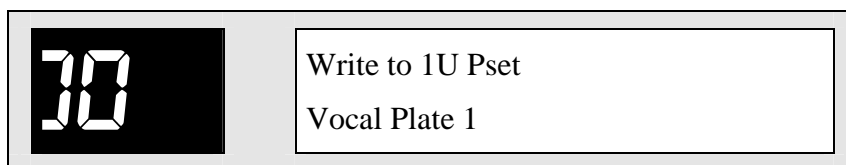

This gives you an opportunity to decide where in the DP/2's memory you'd like to save your 1-Unit Preset. The DP/2 provides 100 possible locations for your work, 00-49 in Bank 1 and 00.-49. in Bank 2. The 1-Unit Presets stored in locations 50 to 99 in both banks are permanent—they can't be written over.

You can use the data entry knob to find a Preset you won't mind replacing with your new one, but for now, let's use location 00.

- Press {WRITE} again.

Now you see:



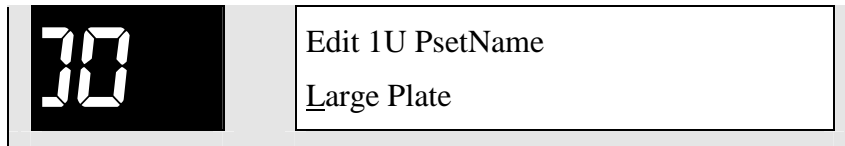

At this point, you can name the new 1-Unit Preset anything that you want (up to 16 characters). For our exercise, we'll name it "My First 1U Pset."

Notice that the "L" on the bottom of the display is underlined. When naming Presets in the DP/2, characters which are underlined may be changed with the data entry knob.

- Turn the data entry knob clockwise to change the "L" to an "M."

The display looks like this:

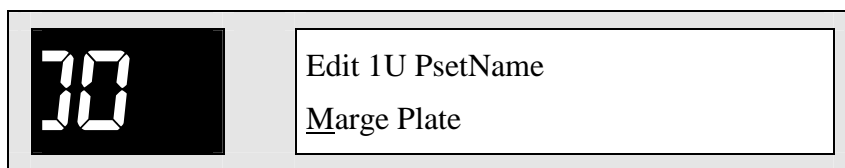

- Press the {>} button once so that the underline moves beneath the "a."
- Turn the data entry knob clockwise until you've dialed in the character "y."
- Continue in this manner—using the {>} button to underline each character in turn, and then changing it with the data entry knob—until you've spelled out:

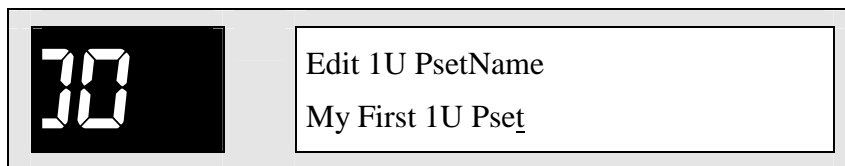

**Tip:** Turn the data entry knob all the way counter-clockwise to dial in the blank spaces.

- When you've finished, press {WRITE} once again.

The display momentarily flashes:

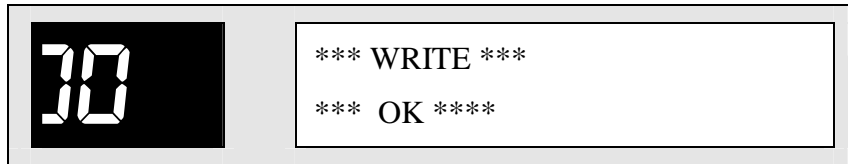

...and your 1-Unit Preset is safely stored at the location you've chosen in the DP/2's memory.

---

## 2-Unit Presets

### Selecting 2-Unit Presets

- Press the {SELECT} button if its LED isn't already lit.

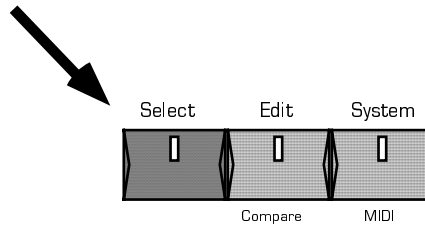

- Press the {CONFIG} button if its light isn't already on.

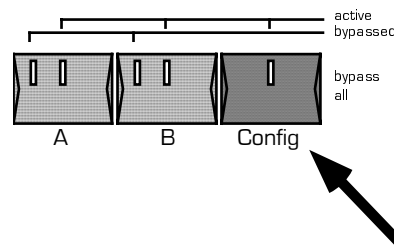

The {SELECT} and {CONFIG} LEDs must be on in order to select 2-Unit Presets.

- Turn the data entry knob—until the display shows:

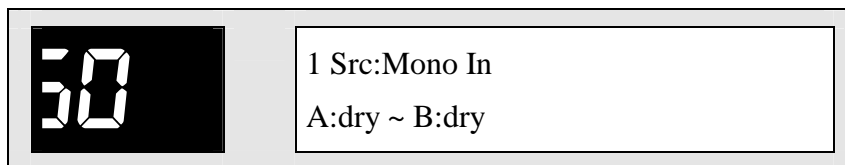

The {SELECT} light is flashing—this means that the DP/2 is waiting for you to confirm your selection.

- Press {SELECT} once more to confirm your choice.
- Press the {A} button. The {A} and {B} yellow LEDs remain lit and the {CONFIG} light goes out .

The display shows:

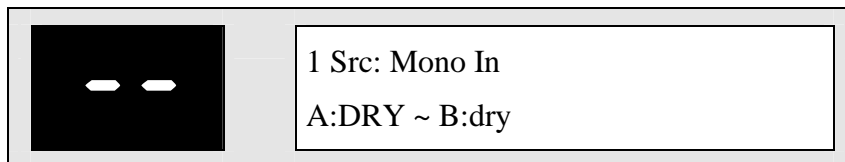

- Turn the data entry knob counter-clockwise until the display reads:



This is “Best Small Space,” the first of the 200 2-Unit Presets stored in the DP/2’s memory. Note that the {SELECT} button is again flashing—the DP/2 is awaiting confirmation of your 2-Unit Preset selection.

- Press {SELECT} to confirm.

Now you can play your instrument, etc. to hear what the 2-Unit Preset “Best Small Space” sounds like.

When you’re ready, you can access the other 199 2-Unit Presets.

The 2-Unit Presets are divided into two groups of 100 Presets each. These groups are called *banks*. The Presets in each bank are numbered from 00-99.

- Turn the data entry knob.

As you turn the data entry knob clockwise, you’ll see the Preset numbers increment from 00 to 99 in Bank 1, and then start over again with 2-Unit Preset 00 of Bank 2.

You can easily tell which bank you’re in by the presence—or absence—of a dot in the lower right-hand corner of the numeric display.

The 2-Unit Presets in Bank 1 look like this:



The 2-Unit Presets in Bank 2 have a dot to the right of the displayed number:



**i**  
dot

**Note:** Sometimes you may see another small dot between the two numerals. This tells you that the DP/2 is receiving MIDI information. *Section 4—System/MIDI* in the DP/2 Reference Manual discusses using MIDI with the DP/2.



- Dial in any of the 2-Unit Presets.
- Press the flashing {SELECT} button to confirm your choice.
- Send the DP/2 some sound.

## Editing 2-Unit Presets

- When you've finished listening to the 2-Unit Presets, go back to Preset 00—"Best Small Space"—and press the flashing {SELECT} button to confirm.
- Press the {EDIT} button.

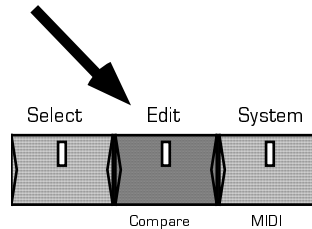

Only Unit A's LED remains lit, so we're going to start by editing the Unit A half of this 2-Unit Preset. The display has changed to:

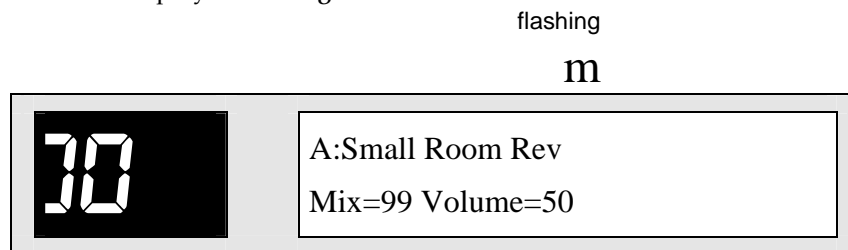

We can now customize "Best Small Space."

Note that the top line in the display is flashing. Many aspects of the DP/2's software can be changed to suit your needs—we call these *parameters*. When a parameter is flashing—like the top line in the display—it is selected for editing. We use the {<} and {>} arrow buttons to select each parameter, and then we use the data entry knob to change the parameter's setting.

We'll start by editing the parameter currently selected—it's the effect used by this half of the 2-Unit Preset.

- Turn the data entry knob slowly clockwise.

What you're now seeing on the bottom line of the display are the names of all the 1-Unit Presets contained in the DP/2's memory—they're the building blocks from which we construct 2-Unit Presets. The top line of the display shows the name of the *algorithm* each 1-Unit Preset is based on—algorithms are the complex mathematical formulae that create the sounds you hear in the DP/2.

A 2-Unit Preset is created by copying single 1-Unit Presets into each of the Preset's two Units—we then edit the copies to suit our purposes. When we save our 2-Unit Preset to the DP/2's memory, we're saving the copies, and are therefore leaving the original, unedited 1-Unit Presets intact.

When we want to change the effect used by one of the Units in a pre-existing 2-Unit Preset, we simply dial in a new 1-Unit Preset as a starting point. That's what we're doing now.

You may have noticed that a moment or so after you stop turning the data entry knob, the display changes somewhat. What's happening is that the DP/2 is automatically copying the 1-Unit Preset you've picked. The bottom line shows the copied Preset's Mix and Volume settings.

You can easily undo any changes you've made by pressing the {UNDO} button.

- Press the {UNDO} button.

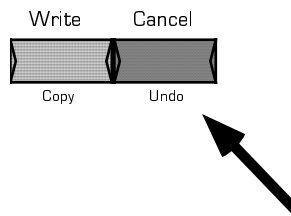

Let's edit some other parameters.

- Press the {>} button once.

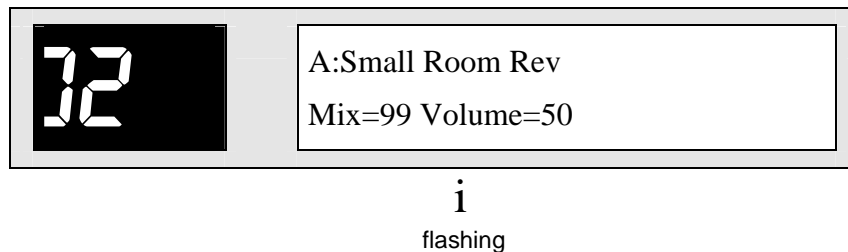

Now the Mix parameter is flashing—we've selected it for editing. This parameter determines how much of Unit A's effect will be added to your original sound.

- Turn the data entry knob counter-clockwise until Mix=50. You've just turned down the effect mix for this half of the 2-Unit Preset.

Each effect in the DP/2 has a number of parameters—many more than those we're currently seeing. Once you start editing an effect, the large red number to the left of the display becomes the number of the parameter that's selected for editing. For more information on the parameters provided for each of the DP/2's effects, see *Section 2—Effect Algorithms* in the DP/2 Reference Manual.

- Press the {>} button twice.

This takes us to the third parameter.

Now we see:

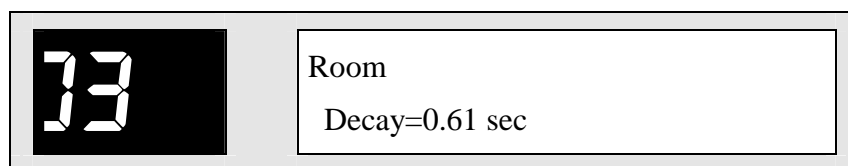

**i**  
flashing

This is the Decay time setting for the reverb in this half of our 2-Unit Preset. The time field is flashing—and therefore selected. Use the data entry knob to change this value if you'd like. To find this effect's other parameters, continue to press the {>} button. When a parameter is flashing, you can alter its setting by using the data entry knob.

You can, of course, go back to previously viewed or edited parameters by pressing the {<} button.

You can also edit Unit B, the other half of the 2-Unit Preset.

- Press the {B} button once to customize Unit B's effect in the same manner.

**Note:** If any of the Units you intend to work with ever has a red LED lit, press that Unit's button once or twice so that only its yellow light is on—otherwise, you won't hear it.

## Saving 2-Unit Presets

Once you've customized a 2-Unit Preset, you can write it into the DP/2's memory and the DP/2 will remember it for you.

- Press the {WRITE} button.

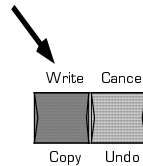

The display shows:

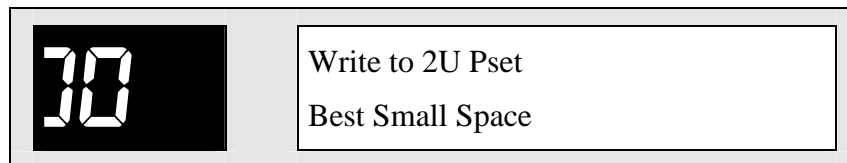

This gives you an opportunity to decide where in the DP/2's memory you'd like to save your 2-Unit Preset. The DP/2 provides 100 possible locations for your work, 00-49 in Bank 1 and 00.-49. in Bank 2. The 2-Unit Presets stored in locations 50 to 99 in both banks are permanent—they can't be written over.

You can use the data entry knob to find a Preset you won't mind replacing with your new one, but for now we'll use location 00.

- Press {WRITE} again.

Now you see:



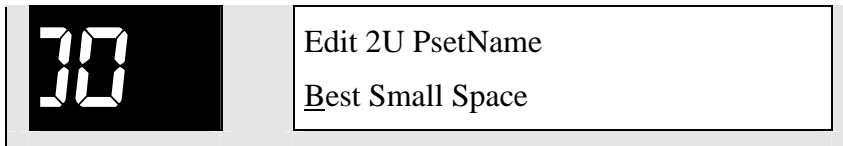

At this point, you can name the new 2-Unit Preset anything that you want (up to 16 characters). For our exercise, we'll name it "My First 2U Preset."

Notice that the "B" on the bottom of the display is underlined. When naming Presets in the DP/2, characters which are underlined may be changed with the data entry knob.

- Turn the data entry knob counter-clockwise to change the "B" to an "M."

The display looks like this:

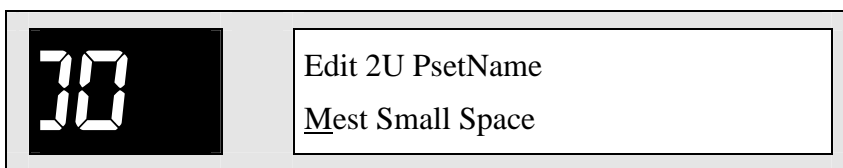

- Press the {>} button once so that the underline moves beneath the "e."
- Turn the data entry knob clockwise until you've dialed in the character "y."
- Continue in this manner—using the {>} button to underline each character in turn,

and then changing it with the data entry knob—until you’ve spelled out:

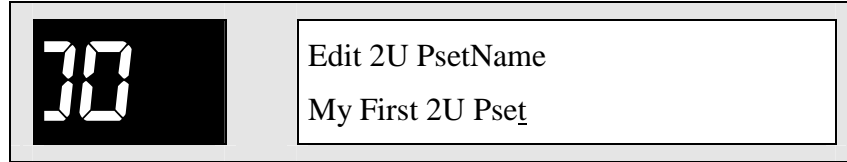

**Tip:** Turn the data entry knob all the way counter-clockwise to dial in the blank spaces.

- When you’ve finished, press {WRITE} once again.

The display momentarily flashes:

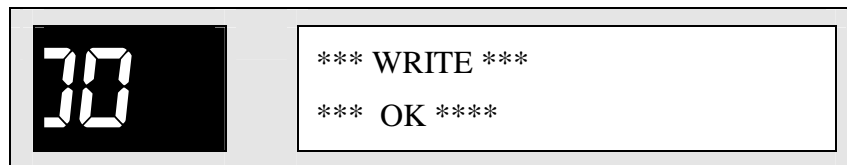

...and your 2-Unit Preset is safely stored at the location you’ve chosen in the DP/2’s memory.

When you save a 2-Unit Preset, the DP/2 also remembers the way that the two Units in the Preset are connected to each other. We discussed these connections in *Section 1—Using the DP/2* in the User’s Guide. They’re also described in *Section 3—Config Parameters* in the DP/2 Reference Manual.

# Section 3

## Quick-Starts

This section of the DP/2 User's Guide contains step-by-step instructions for a number of tasks the DP/2 can perform. The chances are good that you'll find a Quick-Start to suit your needs.

Don't believe for a moment, though, that the following Quick-Starts represent all of the things a DP/2 can do. They're just meant to help you get started with your powerful new effects processor.

### Inside this Section

Acoustic Guitar—Microphone .....	1
Acoustic Guitar—Pickup .....	2
Darth Meets Alvin .....	3
Drum Kit—Ballad Reverbs .....	4
Drum Kit—Dance Hard .....	5
Drum Kit—Dance Soft .....	6
Drum Kit—Gated Room Sound .....	7
Drum Kit—General Purpose Reverbs .....	8
Drum Kit—Rock Reverbs.....	9
Electric Bass—Clean .....	10
Electric Bass—Funk .....	11
Electric Bass—Rock.....	12
Electric Guitar—Chorused.....	13
Electric Guitar—Clean Amp.....	14
Electric Guitar—Clean and Dry .....	15
Electric Guitar—Rock .....	16
Instant Karaoke .....	17
Keyboard—Electric Piano Panner .....	18
Keyboard—Synth Fattener .....	19
MC Effects.....	20
Mixing in Mono.....	21
Mixing in Stereo .....	22
Public Speaking.....	23
Singer/Guitarist.....	24
Solo Instrument—New Age .....	25
Solo Instrument—Rock .....	26
Telephone Filter Effect .....	27
Using Foot Switches .....	28
Vocal—Ballad .....	29
Vocal—Duet.....	30
Vocal—Pop .....	31
Vocal—Rock .....	32
Vocal—Rockabilly.....	33
Vocoder .....	34

Voice-Over with Music Bed..... 35

# Acoustic Guitar—Microphone

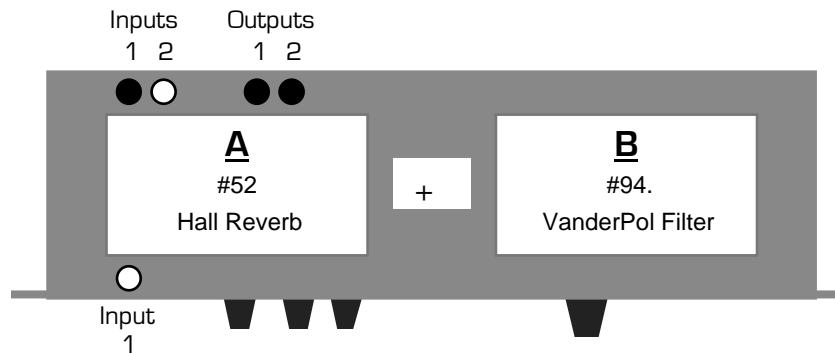

This Quick-Start provides a full-bodied reverb and a VanderPol filter, which helps bring out the real-life sound of your guitar.

1. Turn the DP/2 **inputs** and **outputs** knobs down all the way (counter-clockwise).
2. Plug your guitar's effect send from your mixer into the DP/2's rear-panel **input 1** jack.
3. Connect cables from the DP/2's back-panel **Output 1** and **2** jacks to two returns on your mixing console. If you've only got one return available, connect a cable from **Output 1**.
4. While playing your guitar, turn the **input 1** knob clockwise until the red **peak** LED just above it is flashing occasionally.
5. Turn the **outputs** knob up until your mixer is receiving the proper level from the DP/2.
6. Press the {SYSTEM/MIDI} button. Press the {>} button until the large red number reads "46." Use the **data entry** knob to dial in "Set All 1U Pset Mixes To Wet=Yes."
7. Press the {EDIT} button, and then the {CONFIG} button.
8. Press the {<} button until parameter 00 is displayed in large red numbers.
9. Use the **data entry** knob to set the DP/2 to "1 Source Config."
10. Press {>} once. Use the **data entry** knob to set the AB Input Select to "mono."
11. Press {>} once. Set the AB Unit Routing to "parallel."
12. Press {>} until "(b)ypass (k)ill" is displayed, and the letter following "A=" is flashing. Dial in the letter "k" (if "k" isn't already displayed). Press {>} again to do the same for Unit B.
13. Press the {A} button. If its red LED is flashing, press it again. Press {<} until the red numbers are flashing. Use the **data entry** knob to dial in #52, Hall Reverb—the "52" will start flashing.
14. Press the {B} button. If its red LED is flashing, press it again. Press {<} until the red numbers are flashing. Dial in #94., Dual Delay. (This will be the second #94 you encounter, and will have a small dot to the right of the numeral.) In a moment, the "94." will begin to flash.
15. To save the set-up, press {CONFIG}. Press {WRITE}. Use the **data entry** knob to select a location in the DP/2's memory. Press {WRITE} again.
16. Name your set-up by using the {>} and {<} buttons to underline each character, and the **data entry** knob to dial in the character you want. When you're done, press {WRITE} again.

**Tip:** To customize either of the effects, press {EDIT}, the appropriate letter and {>} or {<} to select its parameters; use the **data entry** knob to edit them. You can change the "Volume=" parameter in an effect to adjust how much of it you'll hear. You can also press the {A} or {B} buttons to turn off either of the processors (its red LED will flash). Press again to turn it back on (the red light will go out). Footswitches can accomplish the same thing—see the "Using Foot Switches" Quick-Start for details.



# Acoustic Guitar—Pickup

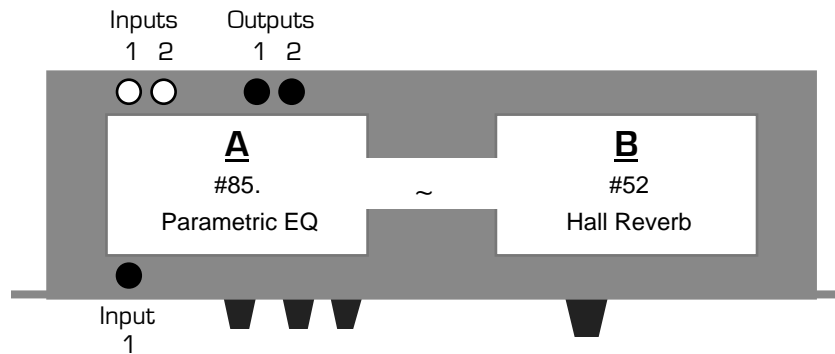

This Quick-Start provides a full-featured parametric equalizer and rich reverb for your guitar. You can utilize the equalizer to shape the tonal characteristics of the guitar's sound.

1. Turn the DP/2 **inputs** and **outputs** knobs down all the way (counter-clockwise).
2. Plug your guitar cord into the DP/2's front-panel **input 1** jack.
3. Connect cables from the DP/2's back-panel **Output 1** and **2** jacks to two inputs on your stereo guitar amplifier or mixing console. If you're going into a single-input guitar amp, connect a cable from the DP/2's **Output 1** to the amp's input.
4. While playing your guitar, turn the **input 1** knob clockwise until the red **peak** LED just above it is flashing occasionally.
5. Turn the **outputs** knob up until your amp (or mixer) is receiving the proper level from the DP/2.
6. Press the {EDIT} button, and then the {CONFIG} button.
7. Press the {<} button until parameter 00 is displayed in large red numbers.
8. Use the **data entry** knob to set the DP/2 to "1 Source Config."
9. Press {>} once. Use the **data entry** knob to set the AB Input Select to "mono."
10. Press {>} once. Set the AB Unit Routing to "serial."
11. Press {>} until "(b)ypass (k)ill" is displayed, and the letter following "A=" is flashing. Dial in the letter "b" (if "b" isn't already displayed). Press {>} again to do the same for Unit B.
12. Press the {A} button. If its red LED is on, press it again. Press {<} until the red numbers are flashing. Use the **data entry** knob to dial in #85., Parametric EQ. (This will be the second #85 you encounter, and will have a small dot to the right of the numeral.) In a moment, the "85." will start flashing.
13. Press the {B} button. If its red LED is on, press it again. Press {<} until the red numbers are flashing. Dial in #52, Hall Reverb—the "52" will begin to flash.
14. Press {>} once. Use the **data entry** knob to set "Mix=" to 30.
15. To save the set-up, press {CONFIG}. Press {WRITE}. Use the **data entry** knob to select a location in the DP/2's memory. Press {WRITE} again.
16. Name your set-up by using the {>} and {<} buttons to underline each character, and the **data entry** knob to dial in the character you want. When you're done, press {WRITE} again.

**Tip:** To customize either of the effects, press {EDIT}, the appropriate letter and {>} or {<} to select its parameters; use the **data entry** knob to edit them. You can change the "Volume=" parameter in an effect to adjust how much of it you'll hear. You can also press the {A} or {B} buttons to turn off either of the processors (its red LED will flash). Press again to turn it back on (the red light will go out). Footswitches can accomplish the same thing—see the "Using Foot Switches" Quick-Start for details.

# Darth Meets Alvin

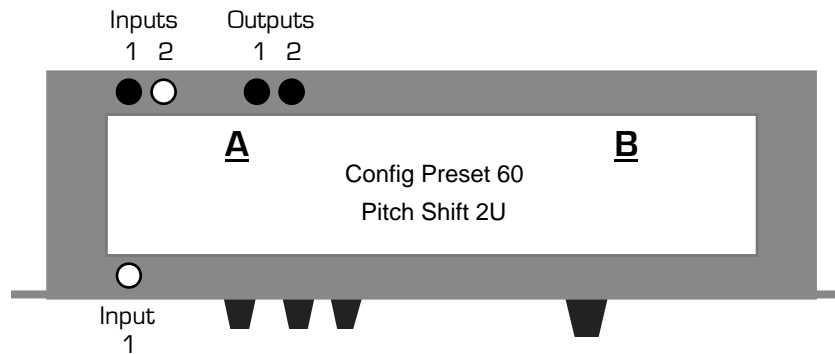

This Quick-Start provides an amusing audio transmogrifying effect.

1. Turn the DP/2 **inputs** and **outputs** knobs down all the way (counter-clockwise).
2. Connect a CV foot pedal (such as ENSONIQ's CVP-1) to the rear-panel **CV•Pedal** jack.
3. Plug a microphone's effect send from your mixer into the DP/2's rear-panel **Input 1** jack.
4. Connect cables from the DP/2's back-panel **Output 1** and **2** jacks to two inputs on your mixer or stereo amplifier. If you're going to a single-input mixer or amp, use only **Output 1**.
5. While speaking, turn the **input 1** knob up until the red **peak** LED above it flashes occasionally.
6. Turn the **outputs** knob up until your mixer (or amp) is receiving the proper level from the DP/2.
7. Set your mixer so that you're only hearing the output of the DP/2, and none of the original "dry" microphone signal.
8. Press the {SELECT} button, and then the {CONFIG} button. Use the **data entry** knob to dial in #60, Pitch Shift 2U. If the red LEDs in the {A} or {B} buttons light up, press {CONFIG} again.
9. Press {SELECT} again.
10. Press the {EDIT} button.
11. Press {>} once. Use the **data entry** knob to set the AB Input Select to "mono."
12. Press {>} until "(b)ypass (k)ill" is displayed, and the letter following "A=" is flashing. Dial in the letter "b" (if "b" isn't already displayed). Press {>} again to do the same for Unit B.
13. Press the {A} button. Press {<} until the red numbers are flashing.
14. Press the {>} button four times so that the "-07" is flashing. Dial in a value of -02.
15. Press {>} four times and use the **data entry** knob to set PitchShifter Vc2 Fine to +02.
16. Using the {>} button and the **data entry** knob, set Mod1 Src to Cntrl-6 DP4 Analog CV In, Mod1 Destination Parameter to 03, Mod1 Param Range to Min=30% and Max=99%. Set Mod2 Src to Cntrl-6 DP4 Analog CV In, Mod2 Destination Parameter to 07, Mod2 Param Range to Min=30% and Max=99%.
17. To save the set-up, press {CONFIG}. Press {WRITE}. Use the **data entry** knob to select a location in the DP/2's memory. Press {WRITE} again.
18. Name your set-up by using the {>} and {<} buttons to underline each character, and the **data entry** knob to dial in the character you want. When you're done, press {WRITE} again.

**Note:** Speak into your microphone with the pedal all the way back to sound like a certain famous promulgator of The Dark Side. Push it forward—you're transformed into a chipmunk!

# Drum Kit—Ballad Reverbs

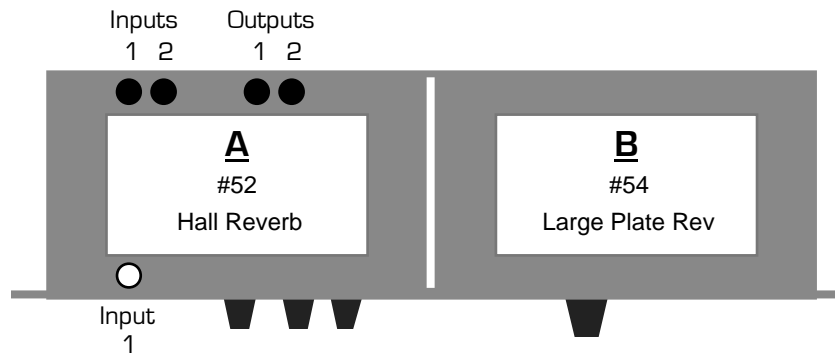

This Quick-Start describes how to set up the DP/2 as two complementary drum kit reverb devices, fed by two separate effect sends from your mixing console. Try using send 1 for your snare and toms, and send 2 for your bass drum and cymbals (including the hi-hat).

1. Connect your mixer's two effect sends to the DP/2's rear-panel **Input 1** and **2** jacks.
2. Connect cables from the DP/2's back-panel **Output 1** and **2** jacks to the effect returns—or faders, if you like—on your mixer. If you've only got one return (or fader), use **Output 1** (and leave **2** unplugged).
3. While sending drum sounds through the two effect sends, turn the DP/2's **input** knobs clockwise until the red **peak** LEDs just above them are flashing occasionally.
4. Turn the **outputs** knob up until your mixer is receiving the proper level from the DP/2.
5. Press the {SYSTEM/MIDI} button. Press the {>} button until the large red number reads "46." Use the **data entry** knob to dial in "Set All 1U Pset Mixes To Wet=Yes."
6. Press the {EDIT} button, and then the {CONFIG} button.
7. Press the {<} button until the large red numbers read "00." Dial in "2 Source Config."
8. Press {>} once. Use the **data entry** knob to set the AB Output Select to "Mixed Stereo."
9. Press {>} until "(b)ypass (k)ill" is displayed, and the letter following "A=" is flashing. Dial in the letter "k" (if "k" isn't already displayed). Press {>} again to do the same for Unit B.
10. Press the {A} button. If its red LED is flashing, press it again. Press {<} until the red numbers are flashing. Dial in #52, Hall Reverb—the "52" will start flashing.
11. Press the {B} button. If its red LED is flashing, press it again. Press {<} until the red numbers are flashing. Dial in #54, Large Plate Rev. In a moment, the "54" will begin to flash.
12. Press {>} twice so that the "99" in "Volume=99" is flashing. Dial in a value of 70.
13. To save the set-up, press {CONFIG}. Press {WRITE}. Use the **data entry** knob to select a location in the DP/2's memory. Press {WRITE} again.
14. Name your set-up by using the {>} and {<} buttons to underline each character, and the **data entry** knob to dial in the character you want. When you're done, press {WRITE} again.

**Tip:** To customize either of the effects, press {EDIT}, the appropriate letter and {>} or {<} to select its parameters; use the **data entry** knob to edit them. You can change the "Volume=" parameter in an effect to adjust how much of it you'll hear. You can also press the {A} or {B} buttons to turn off either of the processors (its red LED will flash). Press again to turn it back on (the red light will go out). Footswitches can accomplish the same thing—see the "Using Foot Switches" Quick-Start for details.

## Drum Kit—Dance Hard

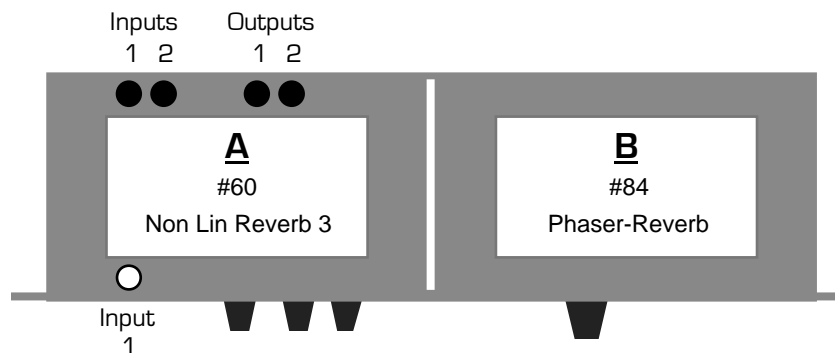

This Quick-Start describes how to set up the DP/2 as two complementary drum kit effect devices, fed by two separate effect sends from your mixing console. Try using send 1 for your drums, and send 2 for your cymbals (including hihat).

1. Connect your mixer's two effect sends to the DP/2's rear-panel **Input 1** and **2** jacks.
2. Connect cables from the DP/2's back-panel **Output 1** and **2** jacks to the effect returns—or faders, if you like—on your mixer. If you've only got one return (or fader), use **Output 1** (and leave **2** unplugged).
3. While sending drum sounds through the two effect sends, turn the DP/2's **input** knobs clockwise until the red **peak** LEDs just above them are flashing occasionally.
4. Turn the **outputs** knob up until your mixer is receiving the proper level from the DP/2.
5. Press the {SYSTEM/MIDI} button. Press the {>} button until the large red number reads "46." Use the **data entry** knob to dial in "Set All 1U Pset Mixes To Wet=Yes."
6. Press the {EDIT} button, and then the {CONFIG} button.
7. Press the {<} button until the large red numbers read "00." Dial in "2 Source Config."
8. Press {>} once. Use the **data entry** knob to set the AB Output Select to "Mixed Stereo."
9. Press {>} until "(b)ypass (k)ill" is displayed, and the letter following "A=" is flashing. Dial in the letter "k" (if "k" isn't already displayed). Press {>} again to do the same for Unit B.
10. Press the {A} button. If its red LED is flashing, press it again. Press {<} until the red numbers are flashing. Dial in #60, Non Lin Reverb 3—the "60" will start flashing.
11. Press the {B} button. If its red LED is flashing, press it again. Press {<} until the red numbers are flashing. Dial in #84, Phaser-Reverb. In a moment, the "84" will begin to flash.
12. Press {>} until "Large Plate Decay" is displayed and "2.89" is flashing. Dial in a value of .43.
13. To save the set-up, press {CONFIG}. Press {WRITE}. Use the **data entry** knob to select a location in the DP/2's memory. Press {WRITE} again.
14. Name your set-up by using the {>} and {<} buttons to underline each character, and the **data entry** knob to dial in the character you want. When you're done, press {WRITE} again.

**Tip:** To customize either of the effects, press {EDIT}, the appropriate letter and {>} or {<} to select its parameters; use the **data entry** knob to edit them. You can change the "Volume=" parameter in an effect to adjust how much of it you'll hear. You can also press the {A} or {B} buttons to turn off either of the processors (its red LED will flash). Press again to turn it back on (the red light will go out). Footswitches can accomplish the same thing—see the "Using Foot Switches" Quick-Start for details.

# Drum Kit—Dance Soft

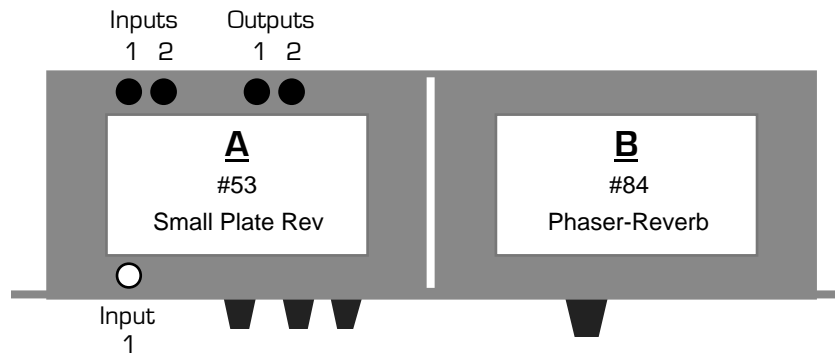

This Quick-Start describes how to set up the DP/2 as two complementary drum kit effect devices, fed by two separate effect sends from your mixing console. Try using send 1 for your drums, and send 2 for your cymbals (including hihat).

1. Connect your mixer's two effect sends to the DP/2's rear-panel **Input 1** and **2** jacks.
2. Connect cables from the DP/2's back-panel **Output 1** and **2** jacks to the effect returns—or faders, if you like—on your mixer. If you've only got one return (or fader), use **Output 1** (and leave **2** unplugged).
3. While sending drum sounds through the two effect sends, turn the DP/2's **input** knobs clockwise until the red **peak** LEDs just above them are flashing occasionally.
4. Turn the **outputs** knob up until your mixer is receiving the proper level from the DP/2.
5. Press the {SYSTEM/MIDI} button. Press the {>} button until the large red number reads "46." Use the **data entry** knob to dial in "Set All 1U Pset Mixes To Wet=Yes."
6. Press the {EDIT} button, and then the {CONFIG} button.
7. Press the {<} button until the large red numbers read "00." Dial in "2 Source Config."
8. Press {>} once. Use the **data entry** knob to set the AB Output Select to "Mixed Stereo."
9. Press {>} until "(b)ypass (k)ill" is displayed, and the letter following "A=" is flashing. Dial in the letter "k" (if "k" isn't already displayed). Press {>} again to do the same for Unit B.
10. Press the {A} button. If its red LED is flashing, press it again. Press {<} until the red numbers are flashing. Dial in #53, Small Plate Rev—the "53" will start flashing.
11. Press the {B} button. If its red LED is flashing, press it again. Press {<} until the red numbers are flashing. Dial in #84, Phaser-Reverb. In a moment, the "84" will begin to flash.
12. To save the set-up, press {CONFIG}. Press {WRITE}. Use the **data entry** knob to select a location in the DP/2's memory. Press {WRITE} again.
13. Name your set-up by using the {>} and {<} buttons to underline each character, and the **data entry** knob to dial in the character you want. When you're done, press {WRITE} again.

**Tip:** To customize either of the effects, press {EDIT}, the appropriate letter and {>} or {<} to select its parameters; use the **data entry** knob to edit them. You can change the "Volume=" parameter in an effect to adjust how much of it you'll hear. You can also press the {A} or {B} buttons to turn off either of the processors (its red LED will flash). Press again to turn it back on (the red light will go out). Footswitches can accomplish the same thing—see the "Using Foot Switches" Quick-Start for details.

# Drum Kit—Gated Room Sound

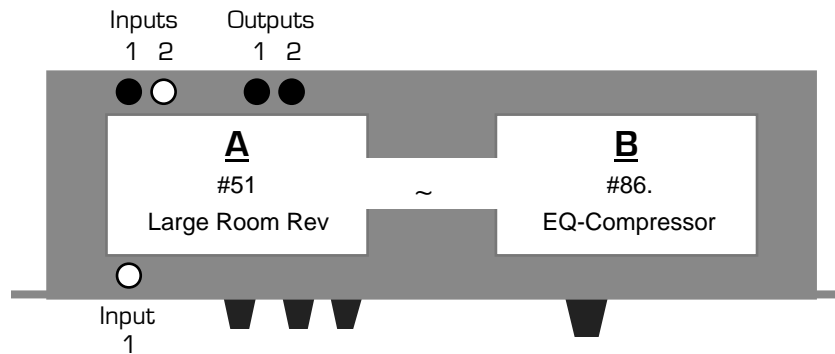

This Quick-Start describes how to get a very popular big rock/pop drum sound.

1. Turn the DP/2 **inputs** and **outputs** knobs down all the way (counter-clockwise).
2. Connect a mono effect send from your mixer to the DP/2's rear-panel **Input 1** jack. Use this send for mono drum sounds such as the snare and/or bass drum.
3. Connect the DP/2's **Outputs 1** and **2** to two effect returns on your mixer. If you'd prefer to use only one mixer return, use **Output 1** and leave **output 2** unplugged.
4. While sending some drum sounds into the DP/2, turn the **input 1** knob clockwise until the red **peak** LEDs just above it is flashing occasionally.
5. Turn the **outputs** knob up until your mixer is receiving the proper level from the DP/2.
6. Press the {SYSTEM/MIDI} button. Press the {>} button until the large red number reads "46." Use the **data entry** knob to dial in "Set All 1U Pset Mixes To Wet=Yes."
7. Press the {EDIT} button, and then the {CONFIG} button.
8. Press the {<} button until the large red numbers read "00." Dial in "1 Source Config."
9. Press {>} once. Use the **data entry** knob to set the AB Input Select to "mono."
10. Press {>} once. Set the AB Unit Routing to "serial."
11. Press {>} until "(b)ypass (k)ill" is displayed, and the letter following "A=" is flashing. Dial in the letter "b" (if "b" isn't already displayed). Press {>} again to do the same for Unit B.
12. Press the {A} button. If its red LED is flashing, press it again. Press {<} until the red numbers are flashing. Dial in #51, Large Room Rev—the "51" will start flashing.
13. Press {>} until "Room Decay" is displayed. Dial in a value of 1.30.
14. Press the {B} button. If its red LED is flashing, press it again. Press {<} until the red numbers are flashing. Dial in #86., EQ-Compressor. (This will be the second #86 you encounter, and will have a small dot to the right of the numeral.) In a moment, the "86" will begin to flash.
15. Use the {>} button and the **data entry** knob to set Compressor Gain to +15, Noise Gate Off Below to -31, Noise Gate On Above to -25 and Gate Release Time to 40ms.
16. To save the set-up, press {CONFIG}. Press {WRITE}. Use the **data entry** knob to select a location in the DP/2's memory. Press {WRITE} again.
17. Name your set-up by using the {>} and {<} buttons to underline each character, and the **data entry** knob to dial in the character you want. When you're done, press {WRITE} again.

# Drum Kit—General Purpose Reverbs

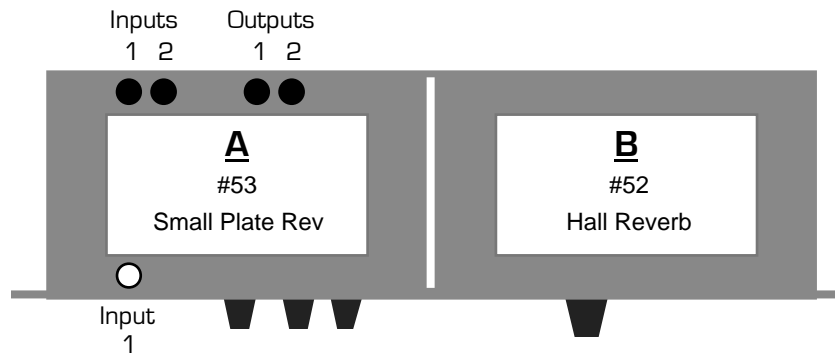

This Quick-Start describes how to set up the DP/2 as two complementary drum kit reverb devices, fed by two separate effect sends from your mixing console. Try using send 1 for your bass drum and cymbals (including the hihat), and send 2 for your snare and toms.

1. Connect your mixer's two effect sends to the DP/2's rear-panel **Input 1** and **2** jacks.
2. Connect cables from the DP/2's back-panel **Output 1** and **2** jacks to the effect returns—or faders, if you like—on your mixer. If you've only got one return (or fader), use **Output 1** (and leave **2** unplugged).
3. While sending drum sounds through the two effect sends, turn the DP/2's **input** knobs clockwise until the red **peak** LEDs just above them are flashing occasionally.
4. Turn the **outputs** knob up until your mixer is receiving the proper level from the DP/2.
5. Press the {SYSTEM/MIDI} button. Press the {>} button until the large red number reads "46." Use the **data entry** knob to dial in "Set All 1U Pset Mixes To Wet=Yes."
6. Press the {EDIT} button, and then the {CONFIG} button.
7. Press the {<} button until the large red numbers read "00." Dial in "2 Source Config."
8. Press {>} once. Use the **data entry** knob to set the AB Output Select to "Mixed Stereo."
9. Press {>} until "(b)ypass (k)ill" is displayed, and the letter following "A=" is flashing. Dial in the letter "k" (if "k" isn't already displayed). Press {>} again to do the same for Unit B.
10. Press the {A} button. If its red LED is flashing, press it again. Press {<} until the red numbers are flashing. Use the **data entry** knob to dial in #53, Small Plate Rev—the "53" will start flashing.
11. Press the {B} button. If its red LED is flashing, press it again. Press {<} until the red numbers are flashing. Dial in #52, Hall Reverb. In a moment, the "52" will begin to flash.
12. To save the set-up, press {CONFIG}. Press {WRITE}. Use the **data entry** knob to select a location in the DP/2's memory. Press {WRITE} again.
13. Name your set-up by using the {>} and {<} buttons to underline each character, and the **data entry** knob to dial in the character you want. When you're done, press {WRITE} again.

**Tip:** To customize either of the effects, press {EDIT}, the appropriate letter and {>} or {<} to select its parameters; use the **data entry** knob to edit them. You can change the "Volume=" parameter in an effect to adjust how much of it you'll hear. You can also press the {A} or {B} buttons to turn off either of the processors (its red LED will flash). Press again to turn it back on (the red light will go out). Footswitches can accomplish the same thing—see the "Using Foot Switches" Quick-Start for details.

# Drum Kit—Rock Reverbs

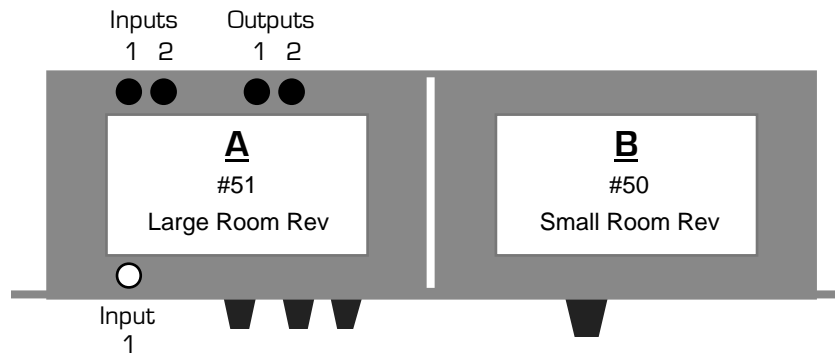

This Quick-Start describes how to set up the DP/2 as two complementary drum kit reverb devices, fed by two separate effect sends from your mixing console. Try using send 1 for your drums, and 2 for your cymbals (and hihat).

1. Connect your mixer's two effect sends to the DP/2's rear-panel **Input 1** and **2** jacks.
2. Connect cables from the DP/2's back-panel **Output 1** and **2** jacks to the effect returns—or faders, if you like—on your mixer. If you've only got one return (or fader), use **Output 1** (and leave **2** unplugged).
3. While sending drum sounds through the two effect sends, turn the DP/2's **input** knobs clockwise until the red **peak** LEDs just above them are flashing occasionally.
4. Turn the **outputs** knob up until your mixer is receiving the proper level from the DP/2.
5. Press the {SYSTEM/MIDI} button. Press the {>} button until the large red number reads "46." Use the **data entry** knob to dial in "Set All 1U Pset Mixes To Wet=Yes."
6. Press the {EDIT} button, and then the {CONFIG} button.
7. Press the {<} button until the large red numbers read "00." Dial in "2 Source Config."
8. Press {>} once. Use the **data entry** knob to set the AB Output Select to "Mixed Stereo."
9. Press {>} until "(b)ypass (k)ill" is displayed, and the letter following "A=" is flashing. Dial in the letter "k" (if "k" isn't already displayed). Press {>} again to do the same for Unit B.
10. Press the {A} button. If its red LED is flashing, press it again. Press {<} until the red numbers are flashing. Use the **data entry** knob to dial in #51, Large Room Rev—the "51" will start flashing.
11. Press the {B} button. If its red LED is flashing, press it again. Press {<} until the red numbers are flashing. Dial in #50, Small Room Rev. In a moment, the "50" will begin to flash.
12. To save the set-up, press {CONFIG}. Press {WRITE}. Use the **data entry** knob to select a location in the DP/2's memory. Press {WRITE} again.
13. Name your set-up by using the {>} and {<} buttons to underline each character, and the **data entry** knob to dial in the character you want. When you're done, press {WRITE} again.

**Tip:** To customize either of the effects, press {EDIT}, the appropriate letter and {>} or {<} to select its parameters; use the **data entry** knob to edit them. You can change the "Volume=" parameter in an effect to adjust how much of it you'll hear. You can also press the {A} or {B} buttons to turn off either of the processors (its red LED will flash). Press again to turn it back on (the red light will go out). Footswitches can accomplish the same thing—see the "Using Foot Switches" Quick-Start for details.



# Electric Bass—Clean

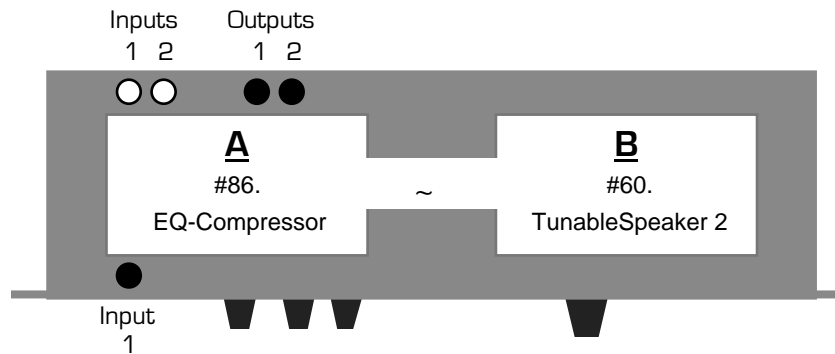

This Quick-Start is designed for bassists recording directly into a mixing console. It provides both a compressor and a clean speaker simulation to make the direct sound a bit less studio-antiseptic.

1. Turn the DP/2 **inputs** and **outputs** knobs down all the way (counter-clockwise).
2. Plug your bass into the DP/2's front-panel **input 1** jack.
3. Connect cables from the DP/2's back-panel **Output 1** and **2** jacks to two inputs on your stereo bass amplifier or mixing console. If you're going into a single-input bass amp or mixer, connect a cable from the DP/2's **Output 1** to that input.
4. While playing your bass, turn the **input 1** knob clockwise until the red **peak** LED just above it is flashing occasionally.
5. Turn the **outputs** knob up until your amp (or mixer) is receiving the proper level from the DP/2.
6. Press the {EDIT} button, and then the {CONFIG} button.
7. Press the {<} button until the large red numbers read "00."
8. Use the **data entry** knob to set the DP/2 to "1 Source Config."
9. Press {>} once. Use the **data entry** knob to set the AB Input Select to "mono."
10. Press {>} once. Set the AB Unit Routing to "serial."
11. Press {>} until "(b)ypass (k)ill" is displayed, and the letter following "A=" is flashing. Dial in the letter "b" (if "b" isn't already displayed). Press {>} again to do the same for Unit B.
12. Press the {A} button. If its red LED is on, press it again. Press {<} until the red numbers are flashing. Use the **data entry** knob to dial in #86., EQ-Compressor. (This will be the second #86 you encounter, and will have a small dot to the right of the numeral.) In a moment, the "86." will start flashing.
13. Press the {B} button. If its red LED is on, press it again. Press {<} until the red numbers are flashing. Dial in #60., TunableSpeaker 2. (This will be the second #60 you encounter, and will have a small dot to the right of the numeral.) In a moment, the "60." will begin to flash.
14. To save the set-up, press {CONFIG}. Press {WRITE}. Use the **data entry** knob to select a location in the DP/2's memory. Press {WRITE} again.
15. Name your set-up by using the {>} and {<} buttons to underline each character, and the **data entry** knob to dial in the character you want. When you're done, press {WRITE} again.

**Tip:** To customize either of the effects, press {EDIT}, the appropriate letter and {>} or {<} to select its parameters; use the **data entry** knob to edit them. You can change the "Volume=" parameter in an effect to adjust how much of it you'll hear. You can also press the {A} or {B} buttons to turn off either of the processors (its red LED will flash). Press again to turn it back on (the red light will go out). Footswitches can accomplish the same thing—see the "Using Foot Switches" Quick-Start for details.

# Electric Bass—Funk

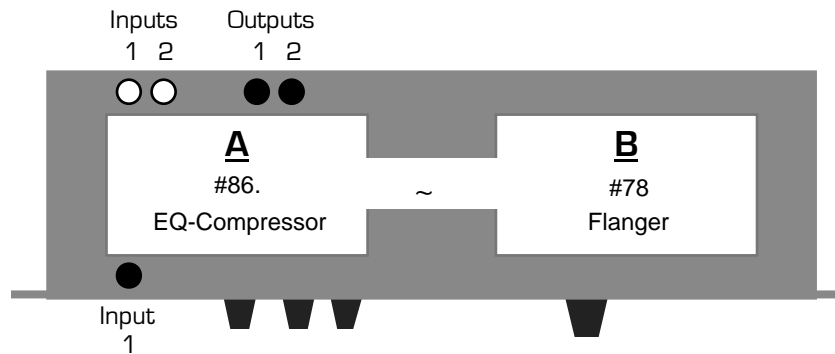

This Quick-Start provides a compressor and a swirling flange effect.

1. Turn the DP/2 **inputs** and **outputs** knobs down all the way (counter-clockwise).
2. Plug your bass into the DP/2's front-panel **input 1** jack.
3. Connect cables from the DP/2's back-panel **Output 1** and **2** jacks to two inputs on your stereo bass amplifier or mixing console. If you're going into a single-input bass amp or mixer, connect a cable from the DP/2's **Output 1** to that input.
4. While playing your bass, turn the **input 1** knob clockwise until the red **peak** LED just above it is flashing occasionally.
5. Turn the **outputs** knob up until your amp (or mixer) is receiving the proper level from the DP/2.
6. Press the {EDIT} button, and then the {CONFIG} button.
7. Press the {<} button until the large red numbers read "00."
8. Use the **data entry** knob to set the DP/2 to "1 Source Config."
9. Press {>} once. Use the **data entry** knob to set the AB Input Select to "mono."
10. Press {>} once. Set the AB Unit Routing to "serial."
11. Press {>} until "(b)ypass (k)ill" is displayed, and the letter following "A=" is flashing. Dial in the letter "b" (if "b" isn't already displayed). Press {>} again to do the same for Unit B.
12. Press the {A} button. If its red LED is on, press it again. Press {<} until the red numbers are flashing. Use the **data entry** knob to dial in #86., EQ-Compressor. (This will be the second #86 you encounter, and will have a small dot to the right of the numeral.) In a moment, the "86." will start flashing.
13. Press the {B} button. If its red LED is on, press it again. Press {<} until the red numbers are flashing. Dial in #78, Flanger—the "78" will begin to flash.
14. To save the set-up, press {CONFIG}. Press {WRITE}. Use the **data entry** knob to select a location in the DP/2's memory. Press {WRITE} again.
15. Name your set-up by using the {>} and {<} buttons to underline each character, and the **data entry** knob to dial in the character you want. When you're done, press {WRITE} again.

**Tip:** To customize either of the effects, press {EDIT}, the appropriate letter and {>} or {<} to select its parameters; use the **data entry** knob to edit them. You can change the "Volume=" parameter in an effect to adjust how much of it you'll hear. You can also press the {A} or {B} buttons to turn off either of the processors (its red LED will flash). Press again to turn it back on (the red light will go out). Footswitches can accomplish the same thing—see the "Using Foot Switches" Quick-Start for details.

# Electric Bass—Rock

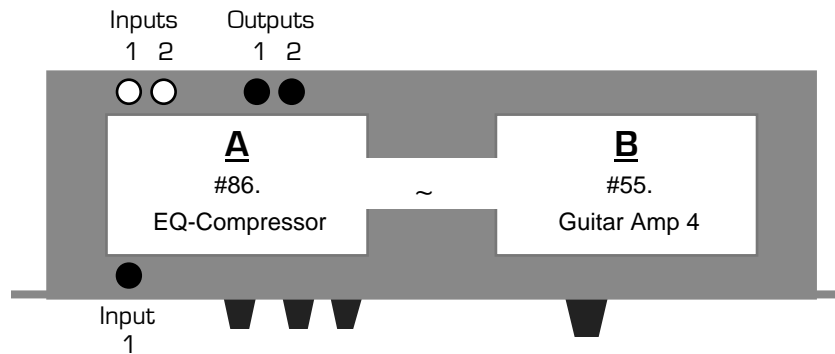

This Quick-Start provides a compressor and an amplifier simulation for studio bassists.

1. Turn the DP/2 **inputs** and **outputs** knobs down all the way (counter-clockwise).
2. Plug your bass into the DP/2's front-panel **input 1** jack.
3. Connect cables from the DP/2's back-panel **Output 1** and **2** jacks to two inputs on your stereo bass amplifier or mixing console. If you're going into a single-input bass amp or mixer, connect a cable from the DP/2's **Output 1** to that input.
4. While playing your bass, turn the **input 1** knob clockwise until the red **peak** LED just above it is flashing occasionally.
5. Turn the **outputs** knob up until your amp (or mixer) is receiving the proper level from the DP/2.
6. Press the {EDIT} button, and then the {CONFIG} button.
7. Press the {<} button until the large red numbers read "00."
8. Use the **data entry** knob to set the DP/2 to "1 Source Config."
9. Press {>} once. Use the **data entry** knob to set the AB Input Select to "mono."
10. Press {>} once. Set the AB Unit Routing to "serial."
11. Press {>} until "(b)ypass (k)ill" is displayed, and the letter following "A=" is flashing. Dial in the letter "b" (if "b" isn't already displayed). Press {>} again to do the same for Unit B.
12. Press the {A} button. If its red LED is on, press it again. Press {<} until the red numbers are flashing. Use the **data entry** knob to dial in #86., EQ-Compressor. (This will be the second #86 you encounter, and will have a small dot to the right of the numeral.) In a moment, the "86." will start flashing.
13. Press the {B} button. If its red LED is on, press it again. Press {<} until the red numbers are flashing. Dial in #55., Guitar Amp 4. (This will be the second #55 you encounter, and will have a small dot to the right of the numeral.) In a moment, the "55." will begin to flash.
14. Press {>} until "Amp PreampGain=30" is displayed. Dial in a value of "+15."
15. To save the set-up, press {CONFIG}. Press {WRITE}. Use the **data entry** knob to select a location in the DP/2's memory. Press {WRITE} again.
16. Name your set-up by using the {>} and {<} buttons to underline each character, and the **data entry** knob to dial in the character you want. When you're done, press {WRITE} again.

**Tip:** To customize either of the effects, press {EDIT}, the appropriate letter and {>} or {<} to select its parameters; use the **data entry** knob to edit them. You can change the "Volume=" parameter in an effect to adjust how much of it you'll hear. You can also press the {A} or {B} buttons to turn off either of the processors (its red LED will flash). Press again to turn it back on (the red light will go out). Footswitches can accomplish the same thing—see the "Using Foot Switches" Quick-Start for details.

# Electric Guitar—Chorused

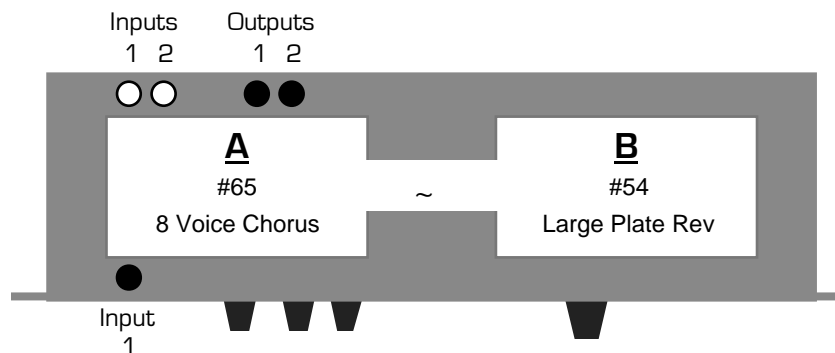

This Quick-Start sends your guitar through a rich chorus effect and then on to a large, clear reverb.

1. Turn the DP/2 **inputs** and **outputs** knobs down all the way (counter-clockwise).
2. Plug your guitar cord into the DP/2's front-panel **input 1** jack.
3. Connect cables from the DP/2's back-panel **Output 1** and **2** jacks to two inputs on your stereo guitar amplifier or mixing console. If you're going into a single-input guitar amp (or mixer), connect a cable from the DP/2's **Output 1** to that input.
4. While playing your guitar, turn the **input 1** knob clockwise until the red **peak** LED just above it is flashing occasionally.
5. Turn the **outputs** knob up until your amp (or mixer) is receiving the proper level from the DP/2.
6. Press the {EDIT} button, and then the {CONFIG} button.
7. Press the {<} button until parameter 00 is displayed in large red numbers.
8. Use the **data entry** knob to set the DP/2 to "1 Source Config."
9. Press {>} once. Use the **data entry** knob to set the AB Input Select to "mono."
10. Press {>} once. Set the AB Unit Routing to "serial."
11. Press {>} until "(b)ypass (k)ill" is displayed, and the letter following "A=" is flashing. Dial in the letter "b" (if "b" isn't already displayed). Press {>} again to do the same for Unit B.
12. Press the {A} button. If its red LED is on, press it again. Press {<} until the red numbers are flashing. Use the **data entry** knob to dial in #65, 8 Voice Chorus. In a moment, the "65" will start flashing.
13. Press {>} until the "00" in "Rate=00" is flashing. Dial in a value of 02.
14. Press the {B} button. If its red LED is on, press it again. Press {<} until the red numbers are flashing. Dial in #54, Large Plate. In a moment, the "54" will begin to flash.
15. To save the set-up, press {CONFIG}. Press {WRITE}. Use the **data entry** knob to select a location in the DP/2's memory. Press {WRITE} again.
16. Name your set-up by using the {>} and {<} buttons to underline each character, and the **data entry** knob to dial in the character you want. When you're done, press {WRITE} again.

**Tip:** To customize any of the effects, press {EDIT}, the appropriate letter and {>} or {<} to select its parameters; use the **data entry** knob to edit them. You can change the "Volume=" parameter in an effect to adjust how much of it you'll hear. You can also press the {A} or {B} buttons to turn off either of the processors (its red LED will flash). Press again to turn it back on (the red light will go out). Footswitches can accomplish the same thing—see the "Using Foot Switches" Quick-Start for details.

# Electric Guitar—Clean Amp

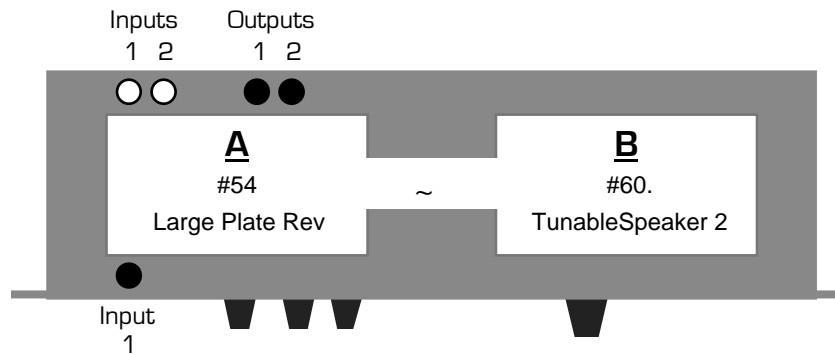

This Quick-Start is designed for guitarists recording directly into a mixing console. It simulates a clean amp set-up by routing the guitar first through a reverb and then into a clean amplifier effect.

1. Turn the DP/2 **inputs** and **outputs** knobs down all the way (counter-clockwise).
2. Plug your guitar cord into the DP/2's front-panel **input 1** jack.
3. Connect cables from the DP/2's back-panel **Output 1** and **2** jacks to two inputs on your stereo guitar amplifier or mixing console. If you're going into a single-input guitar amp or mixer, connect a cable from the DP/2's **Output 1** to that input.
4. While playing your guitar, turn the **input 1** knob clockwise until the red **peak** LED just above it is flashing occasionally.
5. Turn the **outputs** knob up until your amp (or mixer) is receiving the proper level from the DP/2.
6. Press the {EDIT} button, and then the {CONFIG} button.
7. Press the {<} button until parameter 00 is displayed in large red numbers.
8. Use the **data entry** knob to set the DP/2 to "1 Source Config."
9. Press {>} once. Use the **data entry** knob to set the AB Input Select to "mono."
10. Press {>} once. Set the AB Unit Routing to "serial."
11. Press {>} until "(b)ypass (k)ill" is displayed, and the letter following "A=" is flashing. Dial in the letter "b" (if "b" isn't already displayed). Press {>} again to do the same for Unit B.
12. Press the {A} button. If its red LED is on, press it again. Press {<} until the red numbers are flashing. Use the **data entry** knob to dial in #54, Large Plate Rev. In a moment, the "54." will start flashing.
13. Press {>} once. Set Mix= to 23.
14. Press the {B} button. If its red LED is on, press it again. Press {<} until the red numbers are flashing. Use the **data entry** knob to dial in #60., TunableSpeaker 2. (This will be the second #60 you encounter, and will have a small dot to the right of the numeral.) In a moment, the "60." will start flashing.
15. To save the set-up, press {CONFIG}. Press {WRITE}. Use the **data entry** knob to select a location in the DP/2's memory. Press {WRITE} again.
16. Name your set-up by using the {>} and {<} buttons to underline each character, and the **data entry** knob to dial in the character you want. When you're done, press {WRITE} again.

**Tip:** To customize either of the effects, press {EDIT}, the appropriate letter and {>} or {<} to select its parameters; use the **data entry** knob to edit them. You can change the "Volume=" parameter in an effect to adjust how much of it you'll hear. You can also press the {A} or {B} buttons to turn off either of the processors (its red LED will flash). Press again to turn it back on (the red light will go out). Footswitches can accomplish the same thing—see the "Using Foot Switches" Quick-Start for details.

# Electric Guitar—Clean and Dry

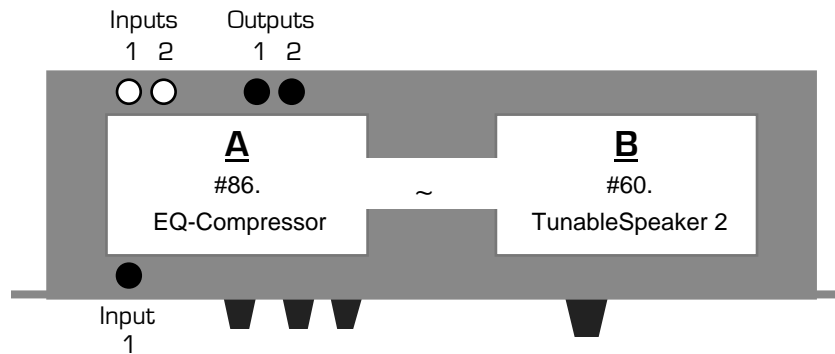

This Quick-Start is designed for guitarists recording directly into a mixing console. It provides both a compressor and a clean speaker simulation to make the direct sound a bit less studio-antiseptic.

1. Turn the DP/2 **inputs** and **outputs** knobs down all the way (counter-clockwise).
2. Plug your guitar cord into the DP/2's front-panel **input 1** jack.
3. Connect cables from the DP/2's back-panel **Output 1** and **2** jacks to two inputs on your stereo guitar amplifier or mixing console. If you're going into a single-input guitar amp or mixer, connect a cable from the DP/2's **Output 1** to that input.
4. While playing your guitar, turn the **input 1** knob clockwise until the red **peak** LED just above it is flashing occasionally.
5. Turn the **outputs** knob up until your amp (or mixer) is receiving the proper level from the DP/2.
6. Press the {EDIT} button, and then the {CONFIG} button.
7. Press the {<} button until parameter 00 is displayed in large red numbers.
8. Use the **data entry** knob to set the DP/2 to "1 Source Config."
9. Press {>} once. Use the **data entry** knob to set the AB Input Select to "mono."
10. Press {>} once. Set the AB Unit Routing to "serial."
11. Press {>} until "(b)ypass (k)ill" is displayed, and the letter following "A=" is flashing. Dial in the letter "b" (if "b" isn't already displayed). Press {>} again to do the same for Unit B.
12. Press the {A} button. If its red LED is on, press it again. Press {<} until the red numbers are flashing. Use the **data entry** knob to dial in #86., EQ-Compressor. (This will be the second #86 you encounter, and will have a small dot to the right of the numeral.) In a moment, the "86." will start flashing.
13. Press the {B} button. If its red LED is on, press it again. Press {<} until the red numbers are flashing. Use the **data entry** knob to dial in #60., TunableSpeaker 2. (This will be the second #60 you encounter, and will have a small dot to the right of the numeral.) In a moment, the "60." will start flashing.
14. To save the set-up, press {CONFIG}. Press {WRITE}. Use the **data entry** knob to select a location in the DP/2's memory. Press {WRITE} again.
15. Name your set-up by using the {>} and {<} buttons to underline each character, and the **data entry** knob to dial in the character you want. When you're done, press {WRITE} again.

**Tip:** To customize either of the effects, press {EDIT}, the appropriate letter and {>} or {<} to select its parameters; use the **data entry** knob to edit them. You can change the "Volume=" parameter in an effect to adjust how much of it you'll hear. You can also press the {A} or {B} buttons to turn off either of the processors (its red LED will flash). Press again to turn it back on (the red light will go out). Footswitches can accomplish the same thing—see the "Using Foot Switches" Quick-Start for details.

# Electric Guitar—Rock

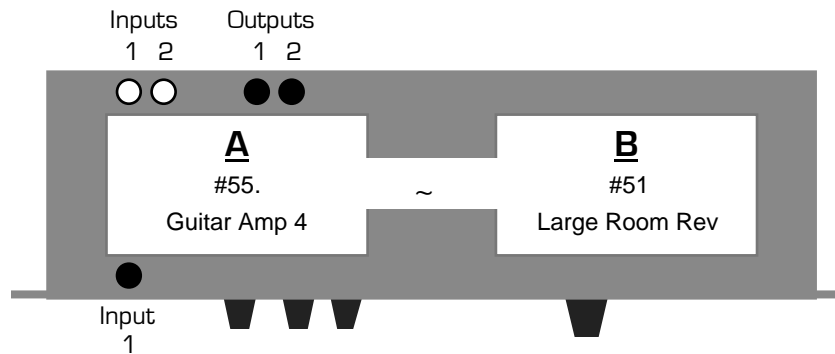

This Quick-Start is designed for guitarists recording directly into a mixing console. It gets its big sound by sending your guitar through a rock amplifier simulation and then into a large room reverb.

1. Turn the DP/2 **inputs** and **outputs** knobs down all the way (counter-clockwise).
2. Plug your guitar cord into the DP/2's front-panel **input 1** jack.
3. Connect cables from the DP/2's back-panel **Output 1** and **2** jacks to two inputs on your stereo guitar amplifier or mixing console. If you're going into a single-input guitar amp or mixer, connect a cable from the DP/2's **Output 1** to that input.
4. While playing your guitar, turn the **input 1** knob clockwise until the red **peak** LED just above it is flashing occasionally.
5. Turn the **outputs** knob up until your amp (or mixer) is receiving the proper level from the DP/2. The **output** knobs should be turned up by an equal amount.
6. Press the {EDIT} button, and then the {CONFIG} button.
7. Press the {<} button until parameter 00 is displayed in large red numbers.
8. Use the **data entry** knob to set the DP/2 to "1 Source Config."
9. Press {>} once. Use the **data entry** knob to set the AB Input Select to "mono."
10. Press {>} once. Set the AB Unit Routing to "serial."
11. Press {>} until "(b)ypass (k)ill" is displayed, and the letter following "A=" is flashing. Dial in the letter "b" (if "b" isn't already displayed). Press {>} again to do the same for Unit B.
12. Press the {A} button. If its red LED is on, press it again. Press {<} until the red numbers are flashing. Use the **data entry** knob to dial in #55., Guitar Amp 4. (This will be the second #55 you encounter, and will have a small dot to the right of the numeral.) In a moment, the "55." will start flashing.
13. Press the {B} button. If its red LED is on, press it again. Press {<} until the red numbers are flashing. Dial in #51, Large Room Rev. In a moment, the "51." will begin to flash.
14. Press {>} once. Set Mix= to 43.
15. To save the set-up, press {CONFIG}. Press {WRITE}. Use the **data entry** knob to select a location in the DP/2's memory. Press {WRITE} again.
16. Name your set-up by using the {>} and {<} buttons to underline each character, and the **data entry** knob to dial in the character you want. When you're done, press {WRITE} again.

**Tip:** To customize either of the effects, press {EDIT}, the appropriate letter and {>} or {<} to select its parameters; use the **data entry** knob to edit them. You can change the "Volume=" parameter in an effect to adjust how much of it you'll hear. You can also press the {A} or {B} buttons to turn off either of the processors (its red LED will flash). Press again to turn it back on (the red light will go out). Footswitches can accomplish the same thing—see the "Using Foot Switches" Quick-Start for details.

# Instant Karaoke

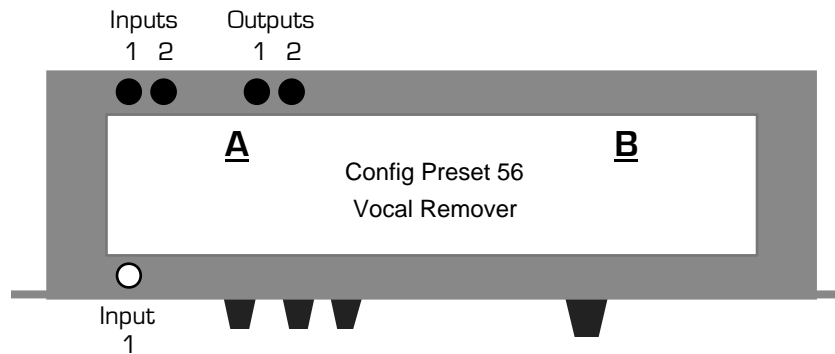

The DP/2 can remove the lead vocals from many recordings, allowing you to step right in as the lead singer. This Quick-Start shows how to do it.

1. Turn the DP/2 **inputs** and **outputs** knobs down all the way (counter-clockwise).
2. Connect the left and right cables from a stereo source (a mixer, cd or cassette player, or turntable, for example) into the DP/2's rear-panel **Input 1** and **2** jacks.
3. Connect cables from the DP/2's back-panel **Output 1** and **2** jacks to two inputs on your mixing console or stereo guitar amplifier. If you're going into a single-input mixer or amp, connect a cable from the DP/2's **Output 1** to that input.
4. While playing the music you want to sing along with, turn the **input 1** and **2** knobs clockwise until the red **peak** LEDs just above **input 1** is flashing occasionally.
5. Turn the **outputs** knob up until your mixer (or amp) is receiving the proper level from the DP/2.
6. Press the {SELECT} button, and then the {CONFIG} button. If the red LEDs in the {A}, {B}, {C} and {D} buttons light up, press {CONFIG} again.
7. Use the **data entry** knob to dial in #56, Vocal Remover.
8. Press {SELECT} again.
9. Press the {EDIT} button.
10. Press the {A} button.
11. Press {>} until the "2000" in "Mid Fc=2000" is flashing. Turn the **data entry** knob up and down to find the best setting for reducing the volume of the lead vocal. Small changes in this setting can be the key to success!

**Note:** If the vocal you're trying to remove has been processed with reverb or other effects, it may not be possible to remove it entirely.



# Keyboard—Electric Piano Panner

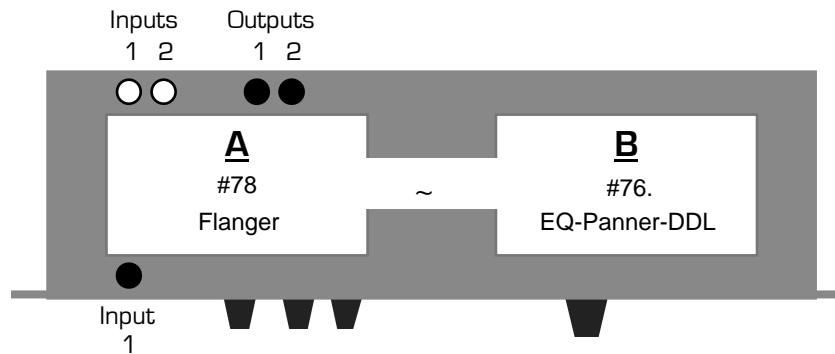

This Quick-Start makes your keyboard swing back-and-forth in the stereo field like an old electric piano. It also provides a flanging effect for an extra bit of swirl, lovely for ballads.

1. Turn the DP/2 **inputs** and **outputs** knobs down all the way (counter-clockwise).
2. Plug your keyboard's output cable into the DP/2's front-panel **input 1** jack. If your keyboard has stereo outputs, plug them into the DP/2's rear-panel **Input** jacks **1** and **2**.
3. Connect cables from the DP/2's back-panel **Output 1** and **2** jacks to two inputs on your stereo guitar amplifier or mixing console. If you're going into a single-input guitar amp or mixer, connect a cable from the DP/2's **Output 1** to that input.
4. While playing your keyboard, turn the **input 1** knob clockwise until the red **peak** LED just above it is flashing occasionally. If your keyboard's stereo, turn up **input 2**'s knob as well.
5. Turn the **outputs** knob up until your amp (or mixer) is receiving the proper level from the DP/2.
6. Press the {EDIT} button, and then the {CONFIG} button.
7. Press the {<} button until the large red numbers read "00."
8. Use the **data entry** knob to set the DP/2 to "1 Source Config."
9. Press {>} once. Set the AB Input Select to "mono," or if your keyboard's stereo, to "stereo."
10. Press {>} once. Set the AB Unit Routing to "serial."
11. Press {>} until "(b)ypass (k)ill" is displayed, and the letter following "A=" is flashing. Dial in the letter "b" (if "b" isn't already displayed). Press {>} again to do the same for Unit B.
12. Press the {A} button. If its red LED is on, press it again. Press {<} until the red numbers are flashing. Use the **data entry** knob to dial in #78, Flanger—the "78" will start flashing.
13. Press the {B} button. If its red LED is on, press it again. Press {<} until the red numbers are flashing. Dial in #76., EQ-Panner-DDL. (This will be the second #76 you encounter, and will have a small dot to the right of the numeral.) In a moment, the "76." will begin to flash.
14. Use the {>} button and the **data entry** knob to set Panner Rate to 65 and Width to 99.
15. To save the set-up, press {CONFIG}. Press {WRITE}. Use the **data entry** knob to select a location in the DP/2's memory. Press {WRITE} again.
16. Name your set-up by using the {>} and {<} buttons to underline each character, and the **data entry** knob to dial in the character you want. When you're done, press {WRITE} again.

**Tip:** To customize either of the effects, press {EDIT}, the appropriate letter and {>} or {<} to select its parameters; use the **data entry** knob to edit them. You can change the "Volume=" parameter in an effect to adjust how much of it you'll hear. You can also press the {A} or {B} buttons to turn off either of the processors (its red LED will flash). Press again to turn it back on (the red light will go out). Footswitches can accomplish the same thing—see the "Using Foot Switches" Quick-Start for details.

# Keyboard—Synth Fattener

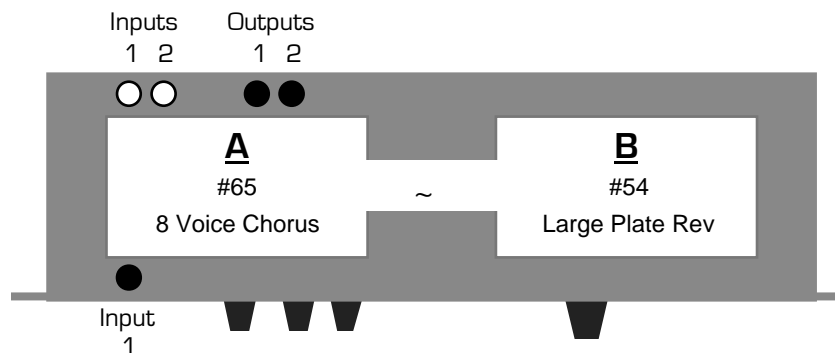

This Quick-Start is for processing a synthesizer with no built-in effects. It runs your dry keyboard through a rich chorus and then on to a large clean reverb to wake up its sound.

1. Turn the DP/2 **inputs** and **outputs** knobs down all the way (counter-clockwise).
2. Plug your keyboard's output cable into the DP/2's front-panel **input 1** jack. If your keyboard has stereo outputs, plug them into the DP/2's rear-panel **Input** jacks **1** and **2**.
3. Connect cables from the DP/2's back-panel **Output 1** and **2** jacks to two inputs on your stereo guitar amplifier or mixing console. If you're going into a single-input guitar amp or mixer, connect a cable from the DP/2's **Output 1** to that input.
4. While playing your keyboard, turn the **input 1** knob clockwise until the red **peak** LED just above it is flashing occasionally. If your keyboard's stereo, turn up **input 2**'s knob as well.
5. Turn the **outputs** knob up until your amp (or mixer) is receiving the proper level from the DP/2.
6. Press the {EDIT} button, and then the {CONFIG} button.
7. Press the {<} button until the large red numbers read "00."
8. Use the **data entry** knob to set the DP/2 to "1 Source Config."
9. Press {>} once. Set the AB Input Select to "mono," or if your keyboard's stereo, to "stereo."
10. Press {>} once. Set the AB Unit Routing to "serial."
11. Press {>} until "(b)ypass (k)ill" is displayed, and the letter following "A=" is flashing. Dial in the letter "b" (if "b" isn't already displayed). Press {>} again to do the same for Unit B.
12. Press the {A} button. If its red LED is on, press it again. Press {<} until the red numbers are flashing. Use the **data entry** knob to dial in #65, 8 Voice Chorus—the "65" will start flashing.
13. Press the {B} button. If its red LED is on, press it again. Press {<} until the red numbers are flashing. Dial in #54, Large Plate Rev. In a moment, the "54" will begin to flash.
14. Press {>} once. Set Mix= to 28.
15. To save the set-up, press {CONFIG}. Press {WRITE}. Use the **data entry** knob to select a location in the DP/2's memory. Press {WRITE} again.
16. Name your set-up by using the {>} and {<} buttons to underline each character, and the **data entry** knob to dial in the character you want. When you're done, press {WRITE} again.

**Tip:** To customize either of the effects, press {EDIT}, the appropriate letter and {>} or {<} to select its parameters; use the **data entry** knob to edit them. You can change the "Volume=" parameter in an effect to adjust how much of it you'll hear. You can also press the {A} or {B} buttons to turn off either of the processors (its red LED will flash). Press again to turn it back on (the red light will go out). Footswitches can accomplish the same thing—see the "Using Foot Switches" Quick-Start for details.

# MC Effects

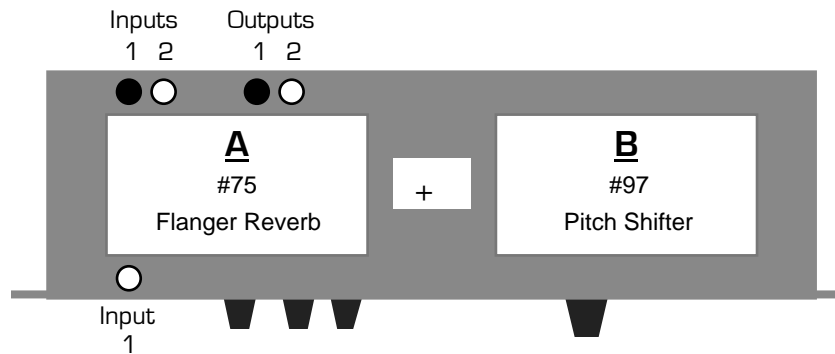

This Quick-Start provides MC's and deejays with some special effects. There's a flanger to make you sound like an alien and a pitch shifter to send your voice way down into the basement.

1. Turn the DP/2 **inputs** and **outputs** knobs down all the way (counter-clockwise).
2. Plug a microphone's effect send from your mixer into the DP/2's rear-panel **Input 1** jack.
3. Connect cables from the DP/2's back-panel **Output 1** jack to an input on your mixing console or stereo amplifier.
4. While speaking, turn the **input 1** knob clockwise until the red **peak** LED just above it is flashing occasionally.
5. Turn the **outputs** knob up until your mixer (or amp) is receiving the proper level from the DP/2.
6. Set your mixer so that you're only hearing the output of the DP/2, and none of the original "dry" microphone signal.
7. Press the {EDIT} button, and then the {CONFIG} button.
8. Press the {<} button until parameter 00 is displayed in large red numbers.
9. Use the **data entry** knob to set the DP/2 to "1 Source Config."
10. Press {>} once. Use the **data entry** knob to set the AB Input Select to "mono."
11. Press {>} once. Set the AB Unit Routing to "parallel."
12. Press {>} until "(b)ypass (k)ill" is displayed, and the letter following "A=" is flashing. Dial in the letter "b" (if "b" isn't already displayed). Press {>} again to do the same for Unit B.
13. Press the {A} button. If its red LED is on, press it again. Press {<} until the red numbers are flashing. Use the **data entry** knob to dial in #75, Flanger-Reverb. In a moment, the "75" will start flashing.
14. Press the {B} button. If its red LED is on, press it again. Press {<} until the red numbers are flashing. Dial in #97, Pitch Shifter—the "97" will begin to flash.
15. Press the button once so that the "40" in "Mix=40" is flashing. Dial in a value of 99.
16. Use the {>} button and **data entry** knob to set PitchShifter Vc1 Fine to -02, PitchShifter Vc2 Semi to -05 and PitchShifter Vc2 Fine to +02.
17. To save the set-up, press {CONFIG}. Press {WRITE}. Use the **data entry** knob to select a location in the DP/2's memory. Press {WRITE} again.
18. Name your set-up by using the {>} and {<} buttons to underline each character, and the **data entry** knob to dial in the character you want. When you're done, press {WRITE} again.

**Tip:** You can press the {A} or {B} buttons to turn off either of the processors (its red LED will light). Press again to turn it back on (the red light will go out). Footswitches can accomplish the same thing—see the "Using Foot Switches" Quick-Start for details.

# Mixing in Mono

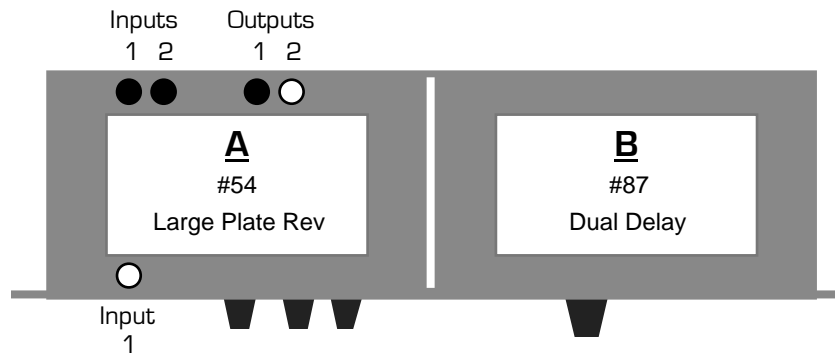

This Quick-Start describes how to set up the DP/2 as two separate effect devices, fed by two separate mono effect sends from your mixing console. It provides a reverb and a delay effect, but you can just as easily dial in any effect that you like at Steps 11 and 12.

1. Connect your mixer's two effect sends to the DP/2's rear-panel **Input 1** and **2** jacks.
2. Connect a cable from the DP/2's back-panel **Output 1** jack to an effect return or fader on your mixer. Don't plug a cable into the DP/2 **Output 2** jack.
3. While sending signal through the two effect sends, turn the DP/2's **input** knobs clockwise until the red **peak** LEDs just above them are flashing occasionally.
4. Turn the **outputs** knob up until your mixer is receiving the proper level from the DP/2.
5. Press the {SYSTEM/MIDI} button. Press the {>} button until the large red number reads "46." Use the **data entry** knob to dial in "Set All 1U Pset Mixes To Wet=Yes."
6. Press the {EDIT} button, and then the {CONFIG} button.
7. Press the {<} button until the large red numbers read "00."
8. Use the **data entry** knob to set the DP/2 to "2 Source Config."
9. Press {>} once. Set the AB Output Select to "Dual Mono."
10. Press {>} until "(b)ypass (k)ill" is displayed, and the letter following "A=" is flashing. Dial in the letter "k" (if "k" isn't already displayed). Press {>} again to do the same for Unit B.
11. Press the {A} button. If its red LED is flashing, press it again. Press {<} until the red numbers are flashing. Dial in #54, Large Plate Rev—the "54" will start flashing.
12. Press the {B} button. If its red LED is flashing, press it again. Press {<} until the red numbers are flashing. Dial in #87, Dual Delay. In a moment, the "87" will begin to flash.
13. To save the set-up, press {CONFIG}. Press {WRITE}. Use the **data entry** knob to select a location in the DP/2's memory. Press {WRITE} again.
14. Name your set-up by using the {>} and {<} buttons to underline each character, and the **data entry** knob to dial in the character you want. When you're done, press {WRITE} again.

**Tip:** To customize either of the effects, press {EDIT}, the appropriate letter and {>} or {<} to select its parameters; use the **data entry** knob to edit them. You can change the "Volume=" parameter in an effect to adjust how much of it you'll hear. You can also press the {A} or {B} buttons to turn off either of the processors (its red LED will flash). Press again to turn it back on (the red light will go out). Footswitches can accomplish the same thing—see the "Using Foot Switches" Quick-Start for details.

# Mixing in Stereo

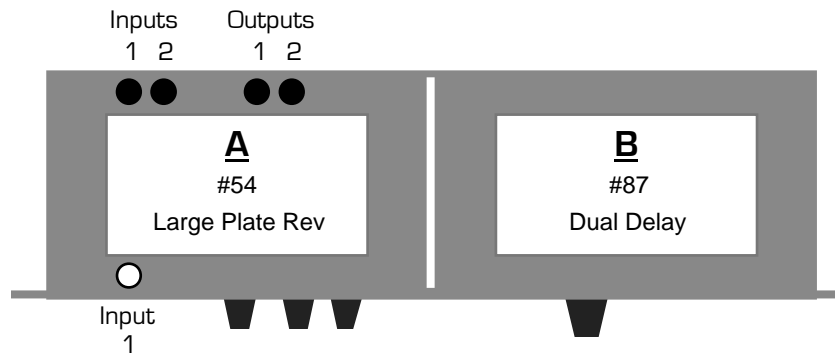

This Quick-Start describes how to set up the DP/2 as two separate effect devices, fed by two separate mono effect sends from your mixing console. It provides a reverb and a delay effect, but you can just as easily dial in any effect that you like at Steps 11 and 12.

1. Connect your mixer's two effect sends to the DP/2's rear-panel **Input 1** and **2** jacks.
2. Connect cables from the DP/2's back-panel **Output 1** and **2** jacks to two effect returns or faders on your mixer.
3. While sending sounds through the two effect sends, turn the DP/2's **input** knobs clockwise until the red **peak** LEDs just above them are flashing occasionally.
4. Turn the **outputs** knob up until your mixer is receiving the proper level from the DP/2.
5. Press the {SYSTEM/MIDI} button. Press the {>} button until the large red number reads "46." Use the **data entry** knob to dial in "Set All 1U Pset Mixes To Wet=Yes."
6. Press the {EDIT} button, and then the {CONFIG} button.
7. Press the {<} button until the large red numbers read "00."
8. Dial in "2 Source Config."
9. Press {>} once. Set the AB Output Select to "Mixed Stereo."
10. Press {>} until "(b)ypass (k)ill" is displayed, and the letter following "A=" is flashing. Dial in the letter "k" (if "k" isn't already displayed). Press {>} again to do the same for Unit B.
11. Press the {A} button. If its red LED is flashing, press it again. Press {<} until the red numbers are flashing. Dial in #54, Large Plate Rev—the "54" will start flashing.
12. Press the {B} button. If its red LED is flashing, press it again. Press {<} until the red numbers are flashing. Dial in #87, Dual Delay. In a moment, the "87" will begin to flash.
13. To save the set-up, press {CONFIG}. Press {WRITE}. Use the **data entry** knob to select a location in the DP/2's memory. Press {WRITE} again.
14. Name your set-up by using the {>} and {<} buttons to underline each character, and the **data entry** knob to dial in the character you want. When you're done, press {WRITE} again.

**Tip:** To customize either of the effects, press {EDIT}, the appropriate letter and {>} or {<} to select its parameters; use the **data entry** knob to edit them. You can change the "Volume=" parameter in an effect to adjust how much of it you'll hear. You can also press the {A} or {B} buttons to turn off either of the processors (its red LED will flash). Press again to turn it back on (the red light will go out). Footswitches can accomplish the same thing—see the "Using Foot Switches" Quick-Start for details.

# Public Speaking

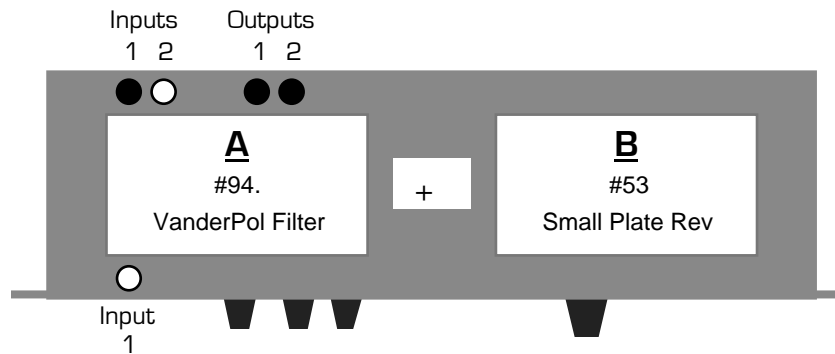

This Quick-Start provides effects to help public speakers sound more clear and natural. The VanderPol filter helps bring out the real-life sound of your voice, while the reverb offers a touch of ambience.

1. Turn the DP/2 **inputs** and **outputs** knobs down all the way (counter-clockwise).
2. Plug a microphone's effect send from your mixer into the DP/2's rear-panel **Input 1** jack.
3. Connect cables from the DP/2's back-panel **Output 1** and **2** jacks to two inputs on your mixing console or stereo guitar amplifier. If you're going into a single-input mixer or amp, connect a cable from the DP/2's **Output 1** to that input.
4. While speaking into your microphone, turn the **input 1** knob clockwise until the red **peak** LED just above it is flashing occasionally.
5. Turn the **outputs** knob up until your mixer (or amp) is receiving the proper level from the DP/2.
6. Press the {EDIT} button, and then the {CONFIG} button.
7. Press the {<} button until the large red numbers read "00."
8. Use the **data entry** knob to set the DP/2 to "1 Source Config."
9. Press {>} once. Use the **data entry** knob to set the AB Input Select to "mono."
10. Press {>} once. Set the AB Unit Routing to "parallel."
11. Press {>} until "(b)ypass (k)ill" is displayed, and the letter following "A=" is flashing. Dial in the letter "k" (if "k" isn't already displayed). Press {>} again to do the same for Unit B.
12. Press the {A} button. If its red LED is flashing, press it again. Press {<} until the red numbers are flashing. Use the **data entry** knob to dial in #94., VanderPol Filter. (This will be the second #94 you encounter, and will have a small dot to the right of the numeral.) In a moment, the "94." will start flashing.
13. Press the {B} button. If its red LED is flashing, press it again. Press {<} until the red numbers are flashing. Dial in #53, Small Plate Rev. In a moment, the "53" will begin to flash.
14. To save the set-up, press {CONFIG}. Press {WRITE}. Use the **data entry** knob to select a location in the DP/2's memory. Press {WRITE} again.
15. Name your set-up by using the {>} and {<} buttons to underline each character, and the **data entry** knob to dial in the character you want. When you're done, press {WRITE} again.

**Tip:** To customize either of the effects, press {EDIT}, the appropriate letter and {>} or {<} to select its parameters; use the **data entry** knob to edit them. You can change the "Volume=" parameter in an effect to adjust how much of it you'll hear. You can also press the {A} or {B} buttons to turn off either of the processors (its red LED will flash). Press again to turn it back on (the red light will go out). Footswitches can accomplish the same thing—see the "Using Foot Switches" Quick-Start for details.

# Singer/Guitarist

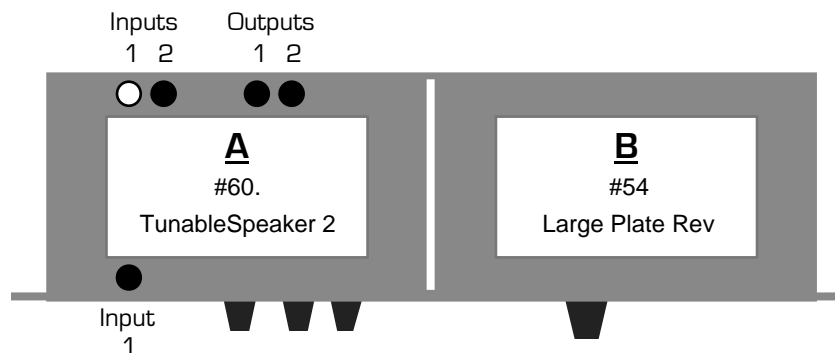

This Quick-Start is for singers who perform with a guitar which has a pick-up. It provides a clean and rich amp simulation for your guitar and a reverb for your voice. MIDI One-Person bands who are using a mono PA system can use this set-up as well, by plugging in their keyboard (or keyboard sub-mixer) into the front-panel **input 1** jack.

1. Turn the DP/2 **input** and **output** knobs down all the way (counter-clockwise).
2. Plug your guitar cord into the DP/2's front-panel **input 1** jack.
3. Connect your vocal's effect send from your mixer to **Input jack 2**.
4. Connect cables from the DP/2's back-panel **Output 1** and **2** jacks to the effect returns on your mixing console. If you've only got one effect return on your mixer, use **Output 1**.
5. While playing your guitar, turn the **input 1** knob clockwise until the red **peak** LED just above it is flashing occasionally.
6. While singing, turn up your vocal's effect sends to a healthy level. Turn the DP/2's **input 2** knob clockwise until the red **peak** LEDs just above it is flashing occasionally.
7. Turn the DP/2 **outputs** knob up until your mixer is receiving the proper level from the DP/2.
8. Press the {EDIT} button, and then the {CONFIG} button.
9. Press the {<} button until parameter 00 is displayed in large red numbers.
10. Use the **data entry** knob to dial in "2 Source Config."
11. Press {>} . Set the AB Output Select to "Mixed Stereo."
12. Press {>} until "(b)ypass (k)ill" is displayed, and the letter following "A=" is flashing. Dial in the letter "b." Press {>} again and dial in "k" for Unit B.
13. Press the {A} button. If its red LED is on, press it again. Press {<} until the red numbers are flashing. Dial in #60., TunableSpeaker 2. (This will be the second #60 you encounter, and will have a small dot to the right of the numeral.) In a moment, the "60." will start flashing.
14. Press the {B} button. If its red LED is flashing, press it again. Press {<} until the red numbers are flashing. Dial in #54, Large Plate Rev—the "54" will begin to flash.
15. Press {>} twice and set Volume= to 50.
16. To save the set-up, press {CONFIG}. Press {WRITE}. Use the **data entry** knob to select a location in the DP/2's memory. Press {WRITE} again.
17. Name your set-up by using the {>} and {<} buttons to underline each character, and the **data entry** knob to dial in the character you want. When you're done, press {WRITE} again.

**Tip:** To customize either of the effects, press {EDIT}, the appropriate letter and {>} or {<} to select its parameters; use the **data entry** knob to edit them. You can change the "Volume=" parameter in an effect to adjust how much of it you'll hear. You can also press the {A} or {B} buttons to turn off either of the processors (its red LED will go on). Press again to turn it back on (the red light will go out). Footswitches can accomplish the same thing—see the "Using Foot Switches" Quick-Start for details.

# Solo Instrument—New Age

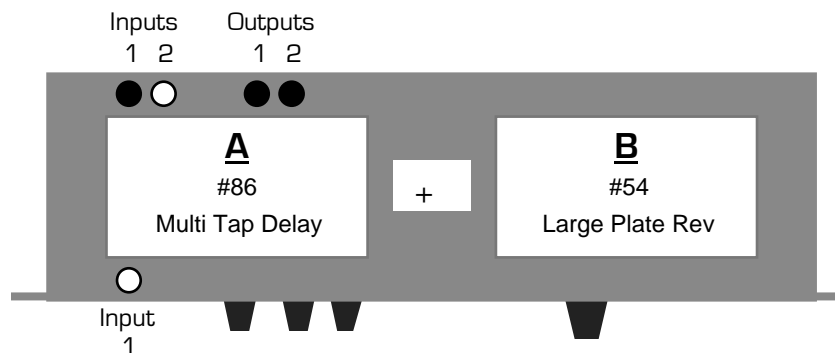

This Quick-Start is for solo wind and reed players performing in a New-Age style.

1. Turn the DP/2 **inputs** and **outputs** knobs down all the way (counter-clockwise).
2. Connect your instrument's effect send from your mixer to the DP/2's rear-panel **Input** jack 1.
3. Connect cables from the DP/2's back-panel **Output 1** and **2** jacks to two inputs on your mixing console or stereo amplifier. If you've only got one input available on your mixer (or amp), connect a cable from the DP/2's **Output 1** to that input.
4. While playing your instrument, turn the **input 1** knob clockwise until the red **peak** LED just above it is flashing occasionally.
5. Turn the **outputs** knob up until your mixer (or amp) is receiving the proper level from the DP/2.
6. Press the {SYSTEM/MIDI} button. Press the {>} button until the large red number reads "46." Use the **data entry** knob to dial in "Set All 1U Pset Mixes To Wet=Yes."
7. Press the {EDIT} button, and then the {CONFIG} button.
8. Press the {<} button until the large red numbers read "00."
9. Use the **data entry** knob to set the DP/2 to "1 Source Config."
10. Press {>} once. Use the **data entry** knob to set the AB Input Select to "mono."
11. Press {>} once. Set the AB Unit Routing to "parallel."
12. Press {>} until "(b)ypass (k)ill" is displayed, and the letter following "A=" is flashing. Dial in the letter "k" (if "k" isn't already displayed). Press {>} again to do the same for Unit B.
13. Press the {A} button. If its red LED is on, press it again. Press {<} until the red numbers are flashing. Use the **data entry** knob to dial in #86, Multi Tap Delay—the "86" will start flashing.
14. Press the {B} button. If its red LED is on, press it again. Press {<} until the red numbers are flashing. Dial in #54, Large Plate Rev. In a moment, the "54" will begin to flash.
15. To save the set-up, press {CONFIG}. Press {WRITE}. Use the **data entry** knob to select a location in the DP/2's memory. Press {WRITE} again.
16. Name your set-up by using the {>} and {<} buttons to underline each character, and the **data entry** knob to dial in the character you want. When you're done, press {WRITE} again.

**Tip:** To customize either of the effects, press {EDIT}, the appropriate letter and {>} or {<} to select its parameters; use the **data entry** knob to edit them. You can change the "Volume=" parameter in an effect to adjust how much of it you'll hear. You can also press the {A} or {B} buttons to turn off either of the processors (its red LED will flash). Press again to turn it back on (the red light will go out). Footswitches can accomplish the same thing—see the "Using Foot Switches" Quick-Start for details.



# Solo Instrument—Rock

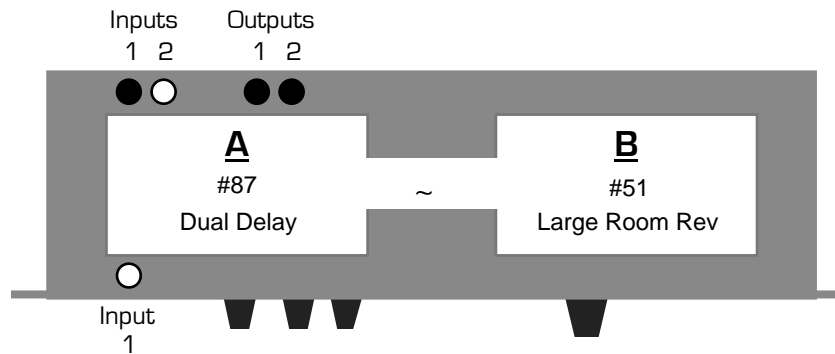

This Quick-Start is for solo reed and wind players performing rock.

1. Turn the DP/2 **inputs** and **outputs** knobs down all the way (counter-clockwise).
2. Connect your instrument's effect send from your mixer to the DP/2's rear-panel **Input** jack 1.
3. Connect cables from the DP/2's back-panel **Output 1** and **2** jacks to two inputs on your mixing console or stereo amplifier. If you've only got one input available on your mixer (or amp), connect a cable from the DP/2's **Output 1** to that input.
4. While playing your instrument, turn the **input 1** knob clockwise until the red **peak** LED just above it is flashing occasionally.
5. Turn the **outputs** knob up until your mixer (or amp) is receiving the proper level from the DP/2.
6. Press the {SYSTEM/MIDI} button. Press the {>} button until the large red number reads "46." Use the **data entry** knob to dial in "Set All 1U Pset Mixes To Wet=Yes."
7. Press the {EDIT} button, and then the {CONFIG} button.
8. Press the {<} button until the large red numbers read "00."
9. Use the **data entry** knob to set the DP/2 to "1 Source Config."
10. Press {>} once. Use the **data entry** knob to set the AB Input Select to "mono."
11. Press {>} once. Set the AB Unit Routing to "serial."
12. Press {>} until "(b)ypass (k)ill" is displayed, and the letter following "A=" is flashing. Dial in the letter "b" (if "b" isn't already displayed). Press {>} again to do the same for Unit B.
13. Press the {A} button. If its red LED is on, press it again. Press {<} until the red numbers are flashing. Use the **data entry** knob to dial in #87, Dual Delay—the "87" will start flashing.
14. Press {>} until "Left Input delay" is displayed and "375" is flashing. Dial in a value of 70. Use the {>} button and the **data entry** knob to set Left Input Delay Regen to 00, Right Input Delay to 98.00, Right input Delay Regen to 00 and Dual Delay Cross Regen to 00.
15. Press the {B} button. If its red LED is on, press it again. Press {<} until the red numbers are flashing. Dial in #51, Large Room Rev. In a moment, the "51" will begin to flash.
16. To save the set-up, press {CONFIG}. Press {WRITE}. Use the **data entry** knob to select a location in the DP/2's memory. Press {WRITE} again.
17. Name your set-up by using the {>} and {<} buttons to underline each character, and the **data entry** knob to dial in the character you want. When you're done, press {WRITE} again.

**Tip:** To customize either of the effects, press {EDIT}, the appropriate letter and {>} or {<} to select its parameters; use the **data entry** knob to edit them. You can change the "Volume=" parameter in an effect to adjust how much of it you'll hear. You can also press the {A} or {B} buttons to turn off either of the processors (its red LED will flash). Press again to turn it back on (the red light will go out). Footswitches can accomplish the same thing—see the "Using Foot Switches" Quick-Start for details.

# Telephone Filter Effect

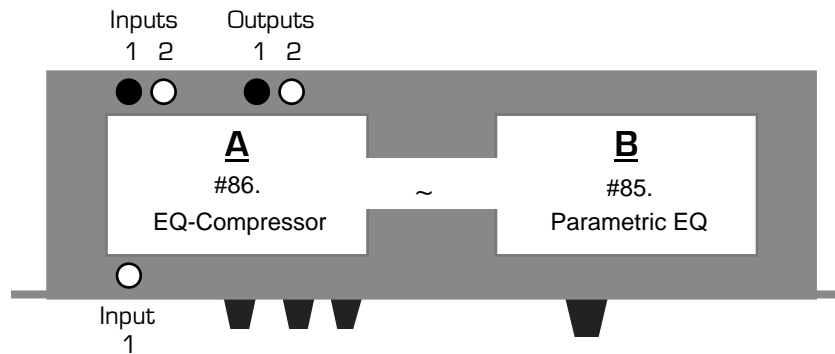

This Quick-Start describes the way to make a voice sound as if it's being heard through a telephone handset.

1. Turn the DP/2 **input** and **output** knobs down all the way (counter-clockwise).
2. Plug a microphone's effect send from your mixer into the DP/2's rear-panel **Input 1** jack.
3. Connect cables from the DP/2's back-panel **Output 1** jack to an input on your mixing console.
4. While speaking into your microphone, turn the **input 1** knob up until the red **peak** LED above it flashes occasionally.
5. Turn the **outputs** knob up until your mixer (or amp) is receiving the proper level from the DP/2.
6. Set your mixer so that you're only hearing the output of the DP/2, and none of the original "dry" microphone signal.
7. Press the {EDIT} button, and then the {CONFIG} button.
8. Press the {<} button until the large red numbers read "00."
9. Use the **data entry** knob to set the DP/2 to "1 Source Config."
10. Press {>} once. Use the **data entry** knob to set the AB Input Select to "mono."
11. Press {>} once. Set the AB Unit Routing to "serial."
12. Press {>} until "(b)ypass (k)ill" is displayed, and the letter following "A=" is flashing. Dial in the letter "b" (if "b" isn't already displayed). Press {>} again to do the same for Unit B.
13. Press the {A} button. If its red LED is on, press it again. Press {<} until the red numbers are flashing. Dial in #86., EQ-Compressor. (This will be the second #86 you encounter, and will have a small dot to the right of the numeral.) In a moment, the "86." will begin to flash.
14. Using the {>} button and **data entry** knob, set Compressor Gain to +05, Comp Ratio to 40:1, Noise Gate Off Below to -96 and Noise Gate On Above to -96.
15. Press the {B} button. If its red LED is on, press it again. Press {<} until the red numbers are flashing. Dial in #85., Parametric EQ. (This will be the second #85 you encounter, and will have a small dot to the right of the numeral.) In a moment, the "85." will begin to flash.
16. Use the {>} button and the **data entry** knob to set Bass Fc to 500 and Bass Gain to -48.
17. Set Mid1 Fc to 1000, Mid1 Gain to +15, Mid Q to 03, Mid2 Fc to 2000, Mid2 Gain to +15 and Mid2 Q to 03. Set Treble Fc to 4KHz and Treble Gain to -48.
18. To save the set-up, press {CONFIG}. Press {WRITE}. Use the **data entry** knob to select a location in the DP/2's memory. Press {WRITE} again.
19. Name your set-up by using the {>} and {<} buttons to underline each character, and the **data entry** knob to dial in the character you want. When you're done, press {WRITE}.

**Tip:** To customize either of the effects, press {EDIT}, the appropriate letter and {>} or {<} to select its parameters; use the **data entry** knob to edit them. You can change the "Volume=" parameter in an effect to adjust how much of it you'll hear. You can also press the {A} or {B} buttons to turn off either of the processors (its red LED will flash). Press again to turn it back on (the red light will go out). Footswitches can accomplish the same thing—see the "Using Foot Switches" Quick-Start for details.

# Using Foot Switches

The DP/2 allows you to use the ENSONIQ SW-10 Dual Foot Switch to turn the DP/2's two effects processors on and off.

To set up your foot pedal:

1. Connect the foot pedal to the **Foot Switch 1** jack on the DP/2's back panel.

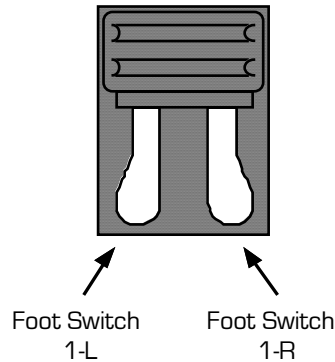

2. Press the {SYSTEM/MIDI} button on the DP/2's front panel.
3. Press the {<} or {>} button until the large red number reads "06" and the top line of the display shows "Unit A Bypass=."
4. Turn the **data entry** knob to dial in "Ftsw 1-L Toggle."
5. Press {>} until the red number shows "13" and the display reads "Unit B Bypass=." Dial in "Ftsw 1-R Toggle."

Each foot pedal is now assigned to its own processor:

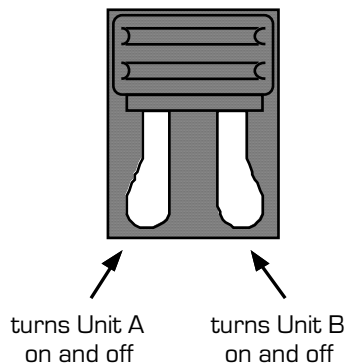

**Note:** Whether it's the effect being switched on and off—or the sound itself—is determined by each Unit's "(b)ypass and (k)ill" setting. See the description of the Bypass/Kill parameter in *Section 3—Config Parameters* in the DP/2 Reference Manual.

# Vocal—Ballad

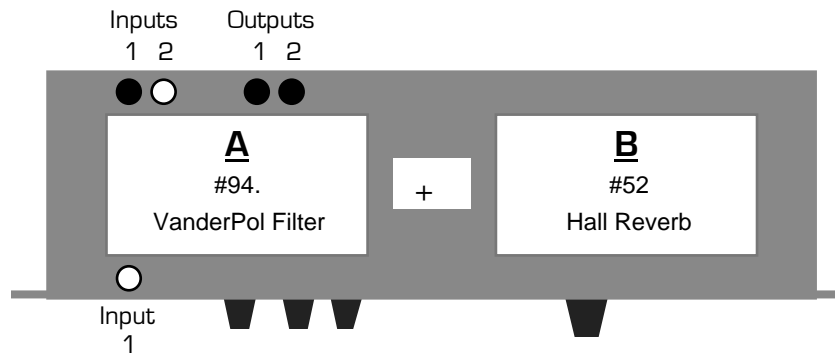

This Quick-Start provides a VanderPol filter, for bringing out the real-life sound of your voice, as well as a large, rich reverb.

1. Turn the DP/2 **inputs** and **outputs** knobs down all the way (counter-clockwise).
2. Plug your vocal's effect send from your mixer into the DP/2's rear-panel **Input 1** jack.
3. Connect cables from the DP/2's back-panel **Output 1** and **2** jacks to two returns on your mixing console. If you've only got one return available, connect a cable from **Output 1**.
4. While singing, turn the **input 1** knob clockwise until the red **peak** LED just above it is flashing occasionally.
5. Turn the **outputs** knob up until your mixer is receiving the proper level from the DP/2.
6. Press the {SYSTEM/MIDI} button. Press the {>} button until the large red number reads "46." Use the **data entry** knob to dial in "Set All 1U Pset Mixes To Wet=Yes."
7. Press the {EDIT} button, and then the {CONFIG} button.
8. Press the {<} button until parameter 00 is displayed in large red numbers.
9. Use the **data entry** knob to set the DP/2 to "1 Source Config."
10. Press {>} once. Use the **data entry** knob to set the AB Input Select to "mono."
11. Press {>} once. Set the AB Unit Routing to "parallel."
12. Press {>} until "(b)ypass (k)ill" is displayed, and the letter following "A=" is flashing. Dial in the letter "k" (if "k" isn't already displayed). Press {>} again to do the same for Unit B.
13. Press the {A} button. If its red LED is flashing, press it again. Press {<} until the red numbers are flashing. Use the **data entry** knob to dial in #94., VanderPol Filter. (This will be the second #94 you encounter, and will have a small dot to the right of the numeral.) In a moment, the "94." will start flashing.
14. Press the {B} button. If its red LED is flashing, press it again. Press {<} until the red numbers are flashing. Dial in #52, Hall Reverb. In a moment, the "52" will begin to flash.
15. Press {>} until "Hall Decay=" is displayed. Dial in "2.91."
16. Press {>} once—"Hall Predelay Time=" is displayed and the "7" is flashing. Dial in "242."
17. To save the set-up, press {CONFIG}. Press {WRITE}. Use the **data entry** knob to select a location in the DP/2's memory. Press {WRITE} again.
18. Name your set-up by using the {>} and {<} buttons to underline each character, and the **data entry** knob to dial in the character you want. When you're done, press {WRITE} again.

**Tip:** To customize either of the effects, press {EDIT}, the appropriate letter and {>} or {<} to select its parameters; use the **data entry** knob to edit them. You can change the "Volume=" parameter in an effect to adjust how much of it you'll hear. You can also press the {A} or {B} buttons to turn off either of the processors (its red LED will flash). Press again to turn it back on (the red light will go out). Footswitches can accomplish the same thing—see the "Using Foot Switches" Quick-Start for details.

# Vocal—Duet

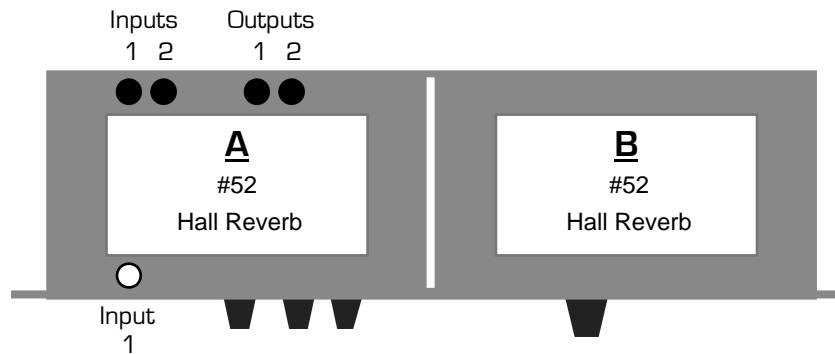

This Quick-Start provides two singer with their own reverbs. It employs the rich Hall Reverb effect, but you can dial in any other reverb you'd like at Steps 12 and 13.

1. Turn the DP/2 **inputs** and **outputs** knobs down all the way (counter-clockwise).
2. Plug one vocal's effect send from your mixer into the DP/2's rear-panel **Input 1** jack and the other's into **Input 2**.
3. Connect cables from the DP/2's back-panel **Output 1** and **2** jacks to two returns on your mixing console. If you've only got one return available, connect a cable from **Output 1** only.
4. While the first vocalist sings, turn the **input 1** knob clockwise until the red **peak** LED just above it is flashing occasionally. Do the same with the second vocalist and **input 2**.
5. Turn the **outputs** knob up until your mixer is receiving the proper level from the DP/2.
6. Press the {SYSTEM/MIDI} button. Press the {>} button until the large red number reads "46." Use the **data entry** knob to dial in "Set All 1U Pset Mixes To Wet=Yes."
7. Press the {EDIT} button, and then the {CONFIG} button.
8. Press the {<} button until parameter 00 is displayed in large red numbers.
9. Use the **data entry** knob to set the DP/2 to "2 Source Config."
10. Press {>} once. Set the AB Output Select to "Mixed Stereo."
11. Press {>} until "(b)ypass (k)ill" is displayed, and the letter following "A=" is flashing. Dial in the letter "k" (if "k" isn't already displayed). Press {>} again to do the same for Unit B.
12. Press the {A} button. If its red LED is flashing, press it again. Press {<} until the red numbers are flashing. Use the **data entry** knob to dial in #52, Hall Reverb—the "52" will start flashing.
13. Press the {B} button. If its red LED is flashing, press it again. Press {<} until the red numbers are flashing. Dial in #52, Hall Reverb. In a moment, the "52" will begin to flash.
14. To save the set-up, press {CONFIG}. Press {WRITE}. Use the **data entry** knob to select a location in the DP/2's memory. Press {WRITE} again.
15. Name your set-up by using the {>} and {<} buttons to underline each character, and the **data entry** knob to dial in the character you want. When you're done, press {WRITE} again.

**Tip:** To customize either of the effects, press {EDIT}, the appropriate letter and {>} or {<} to select its parameters; use the **data entry** knob to edit them. You can change the "Volume=" parameter in an effect to adjust how much of it you'll hear. You can also press the {A} or {B} buttons to turn off either of the processors (its red LED will flash). Press again to turn it back on (the red light will go out). Footswitches can accomplish the same thing—see the "Using Foot Switches" Quick-Start for details.

# Vocal—Pop

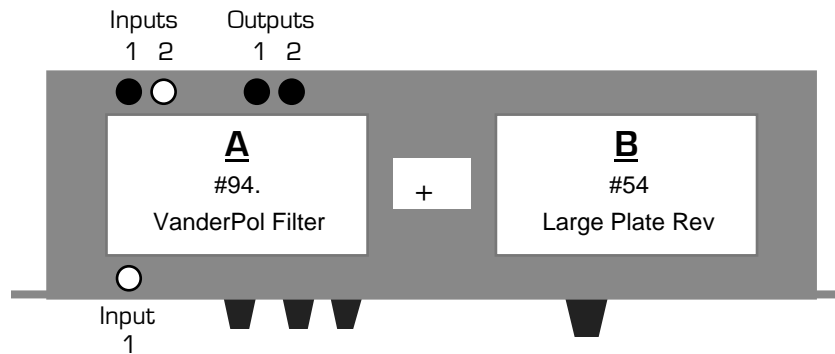

This Quick-Start provides a VanderPol filter, for bringing out the real-life sound of your voice, as well as a large, clear reverb.

1. Turn the DP/2 **inputs** and **outputs** knobs down all the way (counter-clockwise).
2. Plug your vocal's effect send from your mixer into the DP/2's rear-panel **Input 1** jack.
3. Connect cables from the DP/2's back-panel **Output 1** and **2** jacks to two returns on your mixing console. If you've only got one return available, connect a cable from **Output 1**.
4. While singing, turn the **input 1** knob clockwise until the red **peak** LED just above it is flashing occasionally.
5. Turn the **outputs** knob up until your mixer is receiving the proper level from the DP/2.
6. Press the {SYSTEM/MIDI} button. Press the {>} button until the large red number reads "46." Use the **data entry** knob to dial in "Set All 1U Pset Mixes To Wet=Yes."
7. Press the {EDIT} button, and then the {CONFIG} button.
8. Press the {<} button until parameter 00 is displayed in large red numbers.
9. Use the **data entry** knob to set the DP/2 to "1 Source Config."
10. Press {>} once. Use the **data entry** knob to set the AB Input Select to "mono."
11. Press {>} once. Set the AB Unit Routing to "parallel."
12. Press {>} until "(b)ypass (k)ill" is displayed, and the letter following "A=" is flashing. Dial in the letter "k" (if "k" isn't already displayed). Press {>} again to do the same for Unit B.
13. Press the {A} button. If its red LED is flashing, press it again. Press {<} until the red numbers are flashing. Use the **data entry** knob to dial in #94., VanderPol Filter. (This will be the second #94 you encounter, and will have a small dot to the right of the numeral.) In a moment, the "94." will start flashing.
14. Press the {B} button. If its red LED is flashing, press it again. Press {<} until the red numbers are flashing. Dial in #54, Large Plate Rev. In a moment, the "54" will begin to flash.
15. To save the set-up, press {CONFIG}. Press {WRITE}. Use the **data entry** knob to select a location in the DP/2's memory. Press {WRITE} again.
16. Name your set-up by using the {>} and {<} buttons to underline each character, and the **data entry** knob to dial in the character you want. When you're done, press {WRITE} again.

**Tip:** To customize either of the effects, press {EDIT}, the appropriate letter and {>} or {<} to select its parameters; use the **data entry** knob to edit them. You can change the "Volume=" parameter in an effect to adjust how much of it you'll hear. You can also press the {A} or {B} buttons to turn off either of the processors (its red LED will flash). Press again to turn it back on (the red light will go out). Footswitches can accomplish the same thing—see the "Using Foot Switches" Quick-Start for details.

# Vocal—Rock

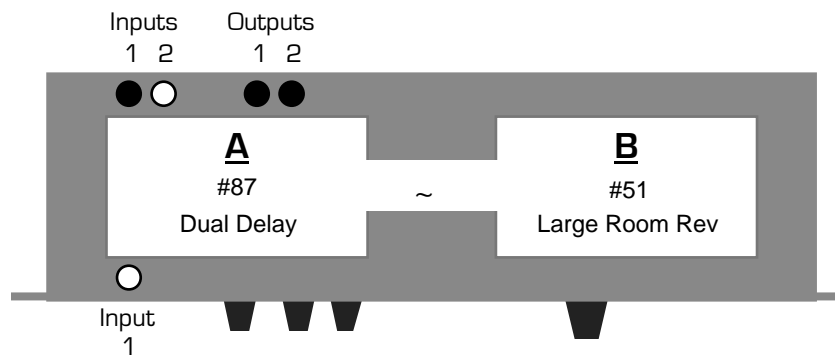

This Quick-Start sends your voice through a short stereo delay effect and then on to a large room reverb.

1. Turn the DP/2 **inputs** and **outputs** knobs down all the way (counter-clockwise).
2. Plug your vocal's effect send from your mixer into the DP/2's rear-panel **Input 1** jack.
3. Connect cables from the DP/2's back-panel **Output 1** and **2** jacks to two returns on your mixing console. If you've only got one return available, connect a cable from **Output 1**.
4. While singing, turn the **input 1** knob up until the red **peak** LED above it flashes occasionally.
5. Turn the **outputs** knob up until your mixer is receiving the proper level from the DP/2.
6. Press the {SYSTEM/MIDI} button. Press the {>} button until the large red number reads "46." Use the **data entry** knob to dial in "Set All 1U Pset Mixes To Wet=Yes."
7. Press the {EDIT} button, {CONFIG}, and then {<} until the large red numbers read "00."
8. Use the **data entry** knob to set the DP/2 to "1 Source Config."
9. Press {>} once. Use the **data entry** knob to set the AB Input Select to "mono."
10. Press {>} once. Set the AB Unit Routing to "serial."
11. Press {>} until "(b)ypass (k)ill" is displayed, and the letter following "A=" is flashing. Dial in the letter "k" (if "k" isn't already displayed). Press {>} again to do the same for Unit B.
12. Press the {A} button. If its red LED is flashing, press it again. Press {<} until the red numbers are flashing. Use the **data entry** knob to dial in #87, Dual Delay—the "87" will start flashing.
13. Press {>} until "Left Input Delay Time=" is displayed. Dial in "115.00 ms."
14. Press {>} until "Left Input Delay Regen=21" is displayed and the "21" is flashing. Dial in "00."
15. Press {>} until "Right Input Delay Time=" is displayed. Dial in "143.00 ms."
16. Press {>} until "Right Input Delay Regen=21" is displayed and the "21" is flashing. Dial in "00."
17. Press {>} until "Dual Delay Cross Regen=" is displayed and the "-47" is flashing. Dial in "00."
18. Press the {B} button. If its red LED is flashing, press it again. Press {<} until the red numbers are flashing. Dial in #51, Large Room Rev. In a moment, the "51" will begin to flash.
19. To save the set-up, press {CONFIG}. Press {WRITE}. Use the **data entry** knob to select a location in the DP/2's memory. Press {WRITE} again.
20. Name your set-up by using the {>} and {<} buttons to underline each character, and the **data entry** knob to dial in the character you want. When you're done, press {WRITE} again.

**Tip:** To customize either of the effects, press {EDIT}, the appropriate letter and {>} or {<} to select its parameters; use the **data entry** knob to edit them. You can change the "Volume=" parameter in an effect to adjust how much of it you'll hear. You can also press the {A} or {B} buttons to turn off either of the processors (its red LED will flash). Press again to turn it back on (the red light will go out). Footswitches can accomplish the same thing—see the "Using Foot Switches" Quick-Start for details.

# Vocal—Rockabilly

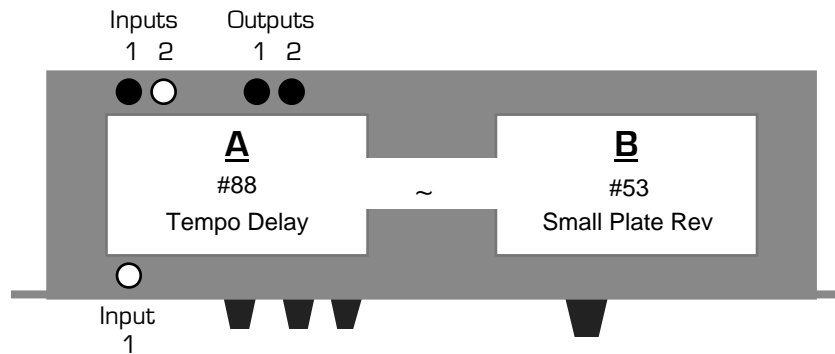

This Quick-Start provides a delay effect that sounds like the tape delay used on vocalists going back to the '50's, as well as a touch of reverb.

1. Turn the DP/2 **inputs** and **outputs** knobs down all the way (counter-clockwise).
2. Plug your vocal's effect send from your mixer into the DP/2's rear-panel **Input 1** jack.
3. Connect cables from the DP/2's back-panel **Output 1** and **2** jacks to two returns on your mixing console. If you've only got one return available, connect a cable from **Output 1**.
4. While singing, turn the **input 1** knob clockwise until the red **peak** LED just above it is flashing occasionally.
5. Turn the **outputs** knob up until your mixer is receiving the proper level from the DP/2.
6. Press the {SYSTEM/MIDI} button. Press the {>} button until the large red number reads "46." Use the **data entry** knob to dial in "Set All 1U Pset Mixes To Wet=Yes."
7. Press the {EDIT} button, and then the {CONFIG} button.
8. Press the {<} button until parameter 00 is displayed in large red numbers.
9. Use the **data entry** knob to set the DP/2 to "1 Source Config."
10. Press {>} once. Use the **data entry** knob to set the AB Input Select to "mono."
11. Press {>} once. Set the AB Unit Routing to "serial."
12. Press {>} until "(b)ypass (k)ill" is displayed, and the letter following "A=" is flashing. Dial in the letter "k" (if "k" isn't already displayed). Press {>} again to do the same for Unit B.
13. Press the {A} button. If its red LED is flashing, press it again. Press {<} until the red numbers are flashing. Use the **data entry** knob to dial in #88, Tempo Delay—the "88" will start flashing.
14. Press {>} until "TempoDelay Time=" is displayed. Dial in "1/8 triplet."
15. Press the {B} button. If its red LED is flashing, press it again. Press {<} until the red numbers are flashing. Dial in #53, Small Plate Rev. In a moment, the "53" will begin to flash.
16. Press {>} once—the "99" in "Mix=41" is flashing. Dial in "35."
17. To save the set-up, press {CONFIG}. Press {WRITE}. Use the **data entry** knob to select a location in the DP/2's memory. Press {WRITE} again.
18. Name your set-up by using the {>} and {<} buttons to underline each character, and the **data entry** knob to dial in the character you want. When you're done, press {WRITE} again.

**Tip:** To customize either of the effects, press {EDIT}, the appropriate letter and {>} or {<} to select its parameters; use the **data entry** knob to edit them. You can change the "Volume=" parameter in an effect to adjust how much of it you'll hear. You can also press the {A} or {B} buttons to turn off either of the processors (its red LED will flash). Press again to turn it back on (the red light will go out). Footswitches can accomplish the same thing—see the "Using Foot Switches" Quick-Start for details.



# Vocoder

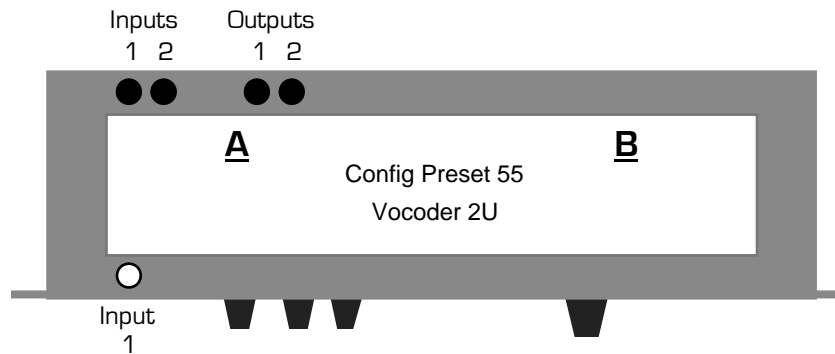

The vocoder is a special effect which first became popular in the 1970's. With a vocoder, you can use your voice to shape sounds played on an instrument, making the notes sound as if they're being spoken or sung. Typically, vocoders are used to shape keyboard sounds, but any sound is fair game, both as shaper and shapee. This Quick-Start will show you how to vocode a keyboard with your voice.

1. Turn the DP/2 **inputs** and **outputs** knobs down all the way (counter-clockwise).
2. Plug a microphone's effect send from your mixer into the DP/2's rear-panel **Input 1** jack.
3. Connect a cable from your keyboard to the DP/2's rear-panel **Input 2** jack.
4. Connect cables from the DP/2's back-panel **Output 1** and **2** jacks to two inputs on your mixing console or stereo guitar amplifier. If you're going into a single-input mixer or amp, connect a cable from the DP/2's **Output 1** to that input.
5. While speaking into your microphone, turn the **input 1** knob clockwise until the red **peak** LED just above it is flashing occasionally. While playing your keyboard, do the same with the **input 2** knob.
6. Turn the **outputs** knob up until your mixer (or amp) is receiving the proper level from the DP/2.
7. Set your mixer so that you're only hearing the output of the DP/2, and none of the original "dry" microphone or keyboard signal.
8. Press the {SELECT} button, and then the {CONFIG} button. If the red LEDs in the {A} or {B} buttons light up, press {CONFIG} again.
9. Use the **data entry** knob to dial in #55, Vocoder 2U.
10. Press {SELECT} again.

Play a chord on the keyboard, hold the keys down, and speak into your microphone. As you speak, the keyboard notes take on the shapes of your words, and yet your voice has no effect on the pitch of the notes (nor is it directly heard in the mix).

**Tip:** You'll find the vocoder works best when the keyboard notes and your voice are in a similar pitch range.

Using the vocoder expressively takes a little practice, as it requires a somewhat different type of mouth-to-hand coordination than you may be used to. Experiment with single-note lines, as well as chords.

# Voice-Over with Music Bed

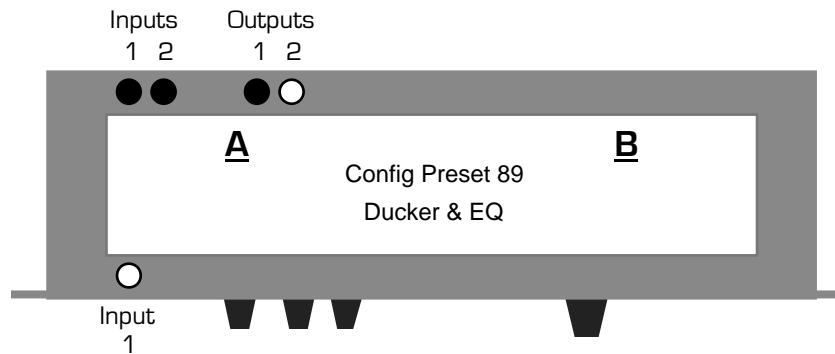

With this Quick-Start, the DP/2 senses the presence of a voice-over announcer and automatically turns the music bed down when he/she is speaking.

1. Turn the DP/2 **inputs** and **outputs** knobs down all the way (counter-clockwise).
2. Connect your music source to the DP/2's rear-panel **Input 1** jack. Don't send the music to your mixer—the DP/2 will take care of that.
3. For the voice-over, plug a microphone's effect send from your mixer into the DP/2's rear-panel **Input 2** jack.
4. Connect the DP/2's **Output 1** to an input on your mixer.
5. While playing your music bed, turn up the **input 1** knob until the red **peak** LEDs above it is flashing occasionally.
6. Running the voice-over through the effect send, do the same with **input 2**.
7. Turn the **outputs** knob up until your mixer is receiving the proper level from the DP/2.
8. Press the {SELECT} button, and then the {CONFIG} button. If the red LEDs in the {A} or {B} buttons light up, press {CONFIG} again.
9. Use the **data entry** knob to dial in #89, Ducker & Gate.
10. Press {SELECT} again.
11. Press the {EDIT} button, and then the {A} button.
12. Press {>} until "Ducker Output Mix" is displayed and "40" is flashing. Dial in a value of 00.
13. Press {>} until "Threshold" is displayed and "-30" is flashing. Dial in a value of -36.
14. Press {>} until "Release" is displayed and "90ms" is flashing. Dial in a value of 200ms.
15. To save the set-up, press {CONFIG}. Press {WRITE}. Use the **data entry** knob to select a location in the DP/2's memory. Press {WRITE} again.
16. Name your set-up by using the {>} and {<} buttons to underline each character, and the **data entry** knob to dial in the character you want. When you're done, press {WRITE} again.

**Tip:** Use your mixer to adjust the volume balance between the voice-over and the music.